

High-speed 1-Needle, Overedging Industrial Sewing Machine

高速一本針オーバーロックミシン

MO-6704S-0E4

High-speed 2-Needle, Overedging Industrial Sewing Machine

高速二本針オーバーロックミシン

MO-6714S-BE6

High-speed Safety Stitch Industrial Sewing Machine

高速安全縫ミシン

MO-6716S-DE4

PARTS LIST

HOW TO MAKE USE OF THIS PARTS LIST

1. Explanation of codes

1) "*" mark.....means this part is changed from the previous parts book.

As to the details of the change, refer to "List for information of change".

2) "01"refer to "Note" explanation at bottom of page.

2. Codes on the "Qty" column

• Each numeral indicates the number of parts required.

• "0.1" and "2.5" indicate the length (in meters) of the respective parts.

3. Parentheses mean that the corresponding part is a subpart that constructs an assembly part.

4. Dotted lines on the Figures indicate assembly parts.

パーツリストご利用に際して

1. "注記" 欄の記号説明

1) "*" 印前回のパーツブックに比較して今回変更された部品を意味します。

変更内容は" 変更情報リスト" を参照してください。

2) "01"ページ下の" 注記" の説明を参照してください。

2. 数量欄の数字は、個数を表し、0.1、2.5等の数値は、長さ（単位メートル）を表します。

3. 数量欄の（ ）は、組部品を構成している子部品であることを意味します。

4. イラストページの — — — — 枠は、組構成であることを意味します。

CONTENTS

目 次

1. MISCELLANEOUS COVER COMPONENTS (1)	1
外装関係 (1)	
2. MISCELLANEOUS COVER COMPONENTS (2)	3
外装関係 (2)	
3. CRANKSHAFT COMPONENTS	5
主軸関係	
4. NEEDLE DRIVING SHAFT COMPONENTS	7
針駆動軸関係	
5. FEED MECHANISM COMPONENTS (1)	9
送り関係 (1)	
6. FEED MECHANISM COMPONENTS (2)	11
送り関係 (2)	
7. UPPER & LOWER LOOPER COMPONENTS	13
上ルーバ、下ルーバ関係	
8. CHAIN LOOPER COMPONENTS (FOR MO-6716S)	15
二重環ルーバ関係(MO-6716S用)	
9. PRESSER FOOT COMPONENTS (1)	16
押さえ関係 (1)	
10. PRESSER FOOT COMPONENTS (2)	17
押さえ関係 (2)	
11. THREAD TENSION COMPONENTS	19
糸調子関係	
12. LOWER KNIFE COMPONENTS	21
下メス関係	
13. UPPER KNIFE COMPONENTS	23
上メス関係	
14. NEEDLE COOLING MECHANISM COMPONENTS (FOR SH)	24
針冷却装置関係 (SH用)	
15. LUBRICATION MECHANISM COMPONENTS	25
給油装置関係	
16. SEMI-SUNKEN TYPE TABLE COMPONENTS	27
卓上式テーブル関係	
17. FULLY-SUNKEN TYPE TABLE COMPONENTS	28
全沈式テーブル関係	
18. STAND COMPONENTS (Z・T)	29
脚関係 (Z・T)	
19. THREAD STAND COMPONENTS (FOR MO-6704S,MO-6714S)	31
糸立装置関係(MO-6704S,MO-6714S用)	
20. THREAD STAND COMPONENTS (MO-6704S,MO-6714S SPECIAL ORDER PARTS)	33
糸立装置関係(MO-6704S,MO-6714 特別注文部品)	

21. THREAD STAND COMPONENTS (FOR MO-6716S)	35
糸立装置関係(MO-6716S用)	
22. THREAD STAND COMPONENTS (MO-6716S SPECIAL ORDER PARTS)	37
糸立装置関係(MO-6716S 特別注文部品)	
23. SPECIAL ORDER PARTS COMPONENTS	39
特別注文部品関係	
24. ACCESSORIES PARTS COMPONENTS	41
付属品関係	
25. LIST FOR INFORMATION OF CHANGE	42
変更情報リスト	
NUMERICAL INDEX OF PARTS	43
索引	

1. MISCELLANEOUS COVER COMPONENTS (1)

外装関係 (1)

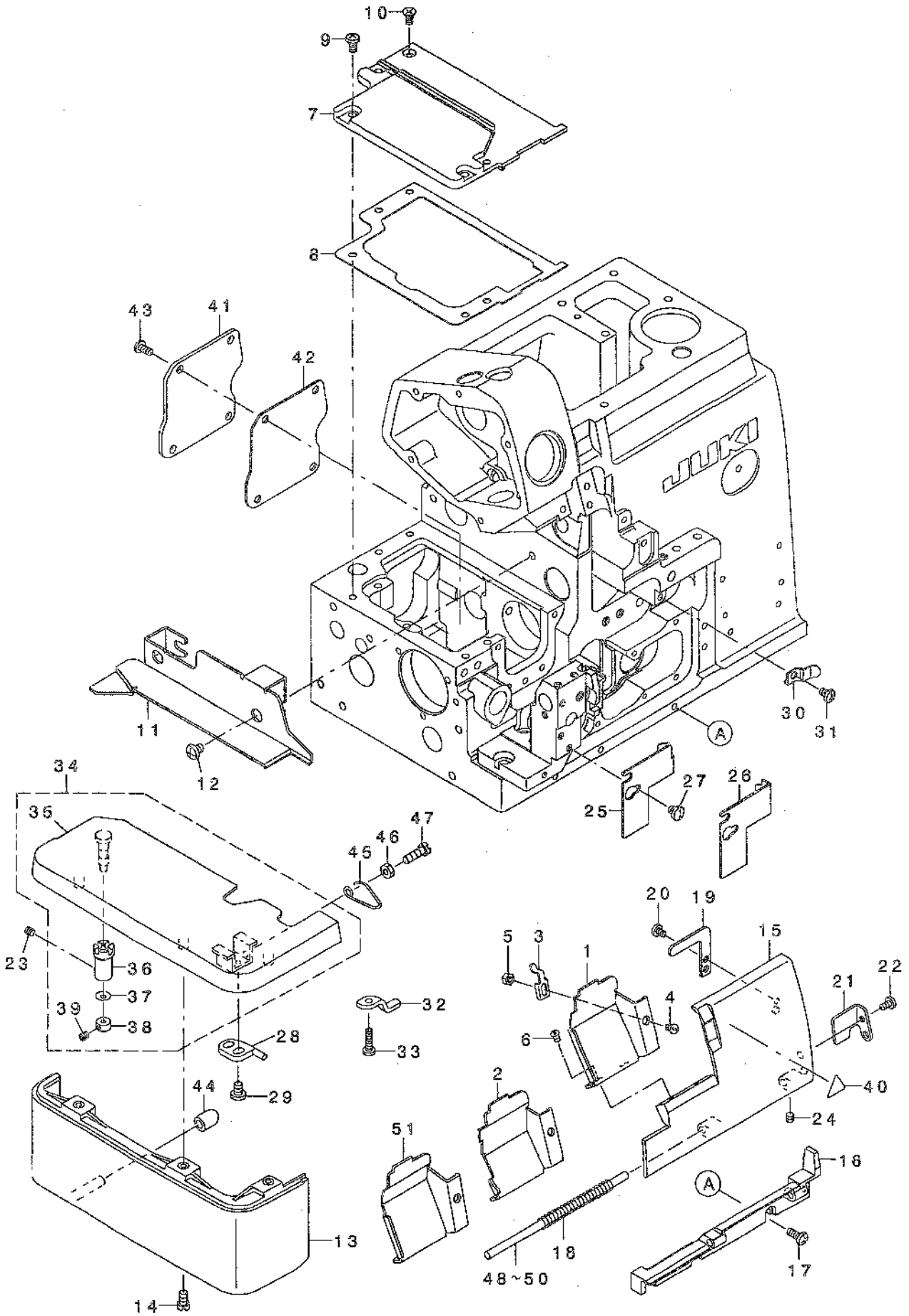

REF. NO	NOTE	PART NO.	DESCRIPTION	品名	Qty
1	04	131-04005	CLOTH WASTE COVER	ヌノクス カハ -	1
2	02	131-04203	CLOTH WASTE COVER	ヌノクス カハ -	1
3		131-02405	CROTH WASTE COVER STOPPER	ヌノクス カハ -ストッパ -	1
4		SS-2090520-SL	SCREW 9/64-40 L=5	マルヒラネジ 9/64-40 L=5	1
5		MS-6090310-SN	NUT 9/64-40	ロツカクナツト 9/64-40	1
6		SS-3090610-SP	SCREW 9/64-40 L=6	マルネジ 9/64-40 L=6	2
7		132-00704	FEED MECHANISM COVER	オクリフタ	1
8		132-00803	FEED MECHANISM COVER GASKET	オクリフタハ ッキン	1
9		SM-4040855-SP	SCREW	ナハ ネジ	4
10		SM-1040801-SC	SCREW M4X0.7 L=8	チラコネジ M4X0.7 L=8	1
11		123-42101	CLOTH BASE SIDE COVER	ヌノダ イヨコカハ -	1
12		SS-4120615-SP	SCREW 3/16-28 L=6	ナハ ネジ 3/16-28 L=6	2
13		131-03809	CLOTH BASE COVER	ヌノダ イカハ -	1
14		SS-4091015-SP	SCREW 9/64-40 L=10	ナハ ネジ 9/64-40 L=10	2
15		131-00904	LOOPER COVER	ルハ -カハ -	1
16		131-00805	LOOPER COVER BRACKET	ルハ -カハ -ウケダ イ	1
17		SM-4041055-SP	SCREW M4 L=10	ナハ ネジ M4 L=10	3
18		131-01209	LOOPER COVER SPRING	ルハ -カハ -ハ ネ	1
19		131-01407	LOOPER COVER PRESSER PLATE	ルハ -カハ -オサエイタ	1
20		SS-7090530-SP	SCREW 9/64-40 L= 4.5	マルヒラネジ 9/64-40 L=4.5	1
21		131-01001	LOOPER COVER GUIDE PLATE	ルハ -カハ -ガ イト イタ	1
22		SS-7090610-SP	SCREW 9/64-40 L=6	マルヒラネジ 9/64-40 L=6	1
23		SS-8110410-TP	SCREW 11/64-40 L= 3.5	トメネジ 11/64-40 L=3.5	1
24		SS-8110410-TP	SCREW 11/64-40 L= 3.5	トメネジ 11/64-40 L=3.5	1
25	01	131-01506	CLOTH WASTE COVER , LEFT	ヌノクス カハ -ヒタ ヲ	1
26	02	131-01605	CLOTH WASTE COVER , LEFT	ヌノクス カハ -ヒタ ヲ	1
27		SS-7110510-SP	SCREW 11/64-40 L=5	マルヒラネジ 11/64-40 L= 5	2
28		121-03305	CLOTH BASE SWITCH-TYPE STOPPER	ヌノダ イ カイハイスツハ -	1
29		SS-7110710-SP	SCREW 11/64-40 L=7	マルヒラネジ 11/64-40 L=7	2
30		131-01308	LOOPER COVER PRESSER SPRING	ルハ -カハ -オサエハ ネ	1
31		SM-4040655-SP	SCREW M4 L=6	ナハ コネジ M4 L=6	1
32		131-01803	CROTH BASE SUPPORT PLATE	ヌノダ イササエイタ	1
33		SS-7091410-SP	SCREW 9/64-40 L=13.5	マルヒラネジ 9/64-40 L=13.5	1
34		131-03650	CLOTH BASE CMPL.	ヌノダ イケツコ ウ	1
35		131-02058	CLOTH BASE ASM.	ヌノダ イタミ	(1)
36		131-01902	CLOTH BASE ECCENTRIC BUSHING	ヌノダ イハシソノア ッツユ	(1)
37		WZ-0420350-KP	DISC SPRING	サラハ ネ	(1)
38		131-72903	CLOTH BASE HINGE SHAFT COLLAR	ヌノダ イヒンジ ツ クカラ-	(1)
39		SM-8040302-TP	SETSCREW	トメネジ	(1)
40		CM-3002000-01	ATTENTION SEAL	ユビ クガ チュウイソ-ル(16)	1
41		132-01504	ADJUSTING HOLE COVER	チヨウセツアナフタ	1
42		132-01603	ADJUSTING HOLE COVER GASKET	チヨウセツアナフタハ ッキン	1
43		SM-4040855-SP	SCREW	ナハ ネジ	4
44		131-04302	CLOTH BASE COVER RUBBER PLUG	ヌノダ イカハ -ホ ウツソコ ム	1
45		131-02207	CLOTH BASE SWITCH-TYPE SPRING	ヌノダ イカイハハ ネ	1
46		NS-6110420-SP	NUT 11/64-40	ロツカクナツト 11/64-40	1
47		SS-6111440-SP	SCREW 11/64-40 L=14.0	ヒラネジ 11/64-40 L=14	1
48	03	132-40007	LOOPER COVER HINGE SHAFT A	ルハ -カハ -ヒンジ ツ クA	1
49	03	132-40106	LOOPER COVER HINGE SHAFT B	ルハ -カハ -ヒンジ ツ クB	1
50	03	132-40205	LOOPER COVER HINGE SHAFT C	ルハ -カハ -ヒンジ ツ クC	1
51	05	131-04104	CLOTH WASTE COVER	ヌノクス カハ -	1

NOTE (注記)

01...	FOR MO-6704S, MO-6714S	MO-6704S, MO-6714S用
02...	FOR MO-6716S	MO-6716S用
03...	SELECTIVE PARTS	選択部品
04...	FOR MO-6704S, MO-6714S (EXCEPT TYPE SH)	MO-6704S, MO-6714S用 (SH仕様を除く)
05...	FOR MO-6704S, MO-6714S (FOR TYPE SH)	MO-6704S, MO-6714S用 (SH仕様のみ)

4. NEEDLE DRIVING SHAFT COMPONENTS

針驅動軸關係

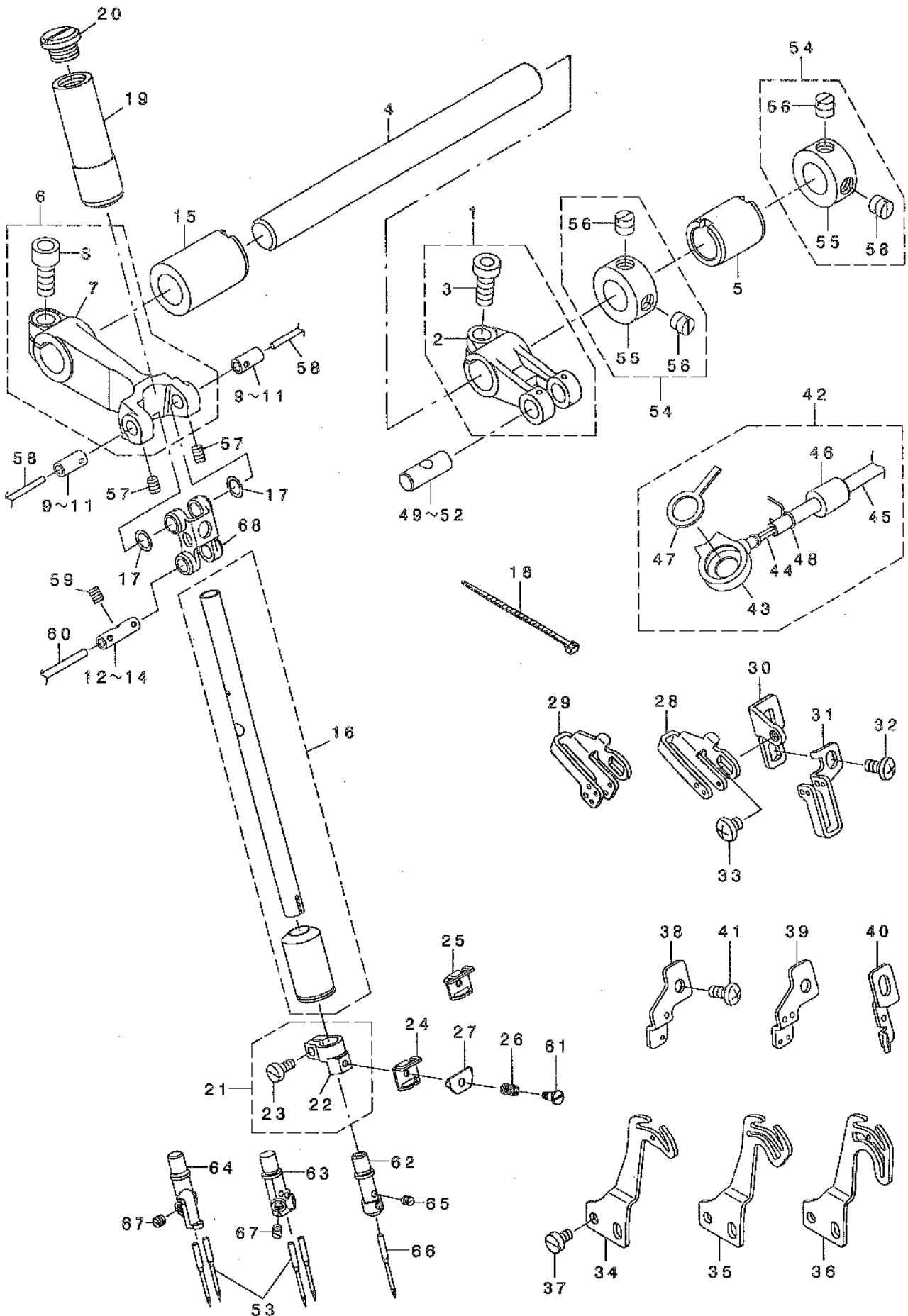

REF. NO	NOTE	PART NO.	DESCRIPTION	品名	Qty
1		131-10556	FEED FORKED CRANK ASM.	ハリクトウ フタマタクランクミ	1
2		131-10507	NEEDLE DRIVING BRANCH CRANK	ハリクトウ フタマタクランク	(1)
3		SM-6061402-TP	SCREW M6 L=14	ロツカクアナネジ M6 L=14	(1)
4		131-10606	NEEDLE DRIVING SHAFT	ハリクトウ ウツク	1
5		131-10101	BUSHING, REAR	ハリクトウ ウツク クワシロメタ	1
6		132-09853	NEEDLE DRIVING ARM ASM.	ハリクトウ ウツデ アミ	1
7		132-09804	NEEDLE DRIVING ARM	ハリクトウ ウツデ	(1)
8		SM-6061402-TP	SCREW M6 L=14	ロツカクアナネジ M6 L=14	(1)
9	07	132-09101	NEEDLE DRIVING ARM PIN A	ハリクトウ ウツデ ビンA	2
10	07	132-09200	NEEDLE DRIVING ARM PIN B	ハリクトウ ウツデ ビンB	2
11	07	132-09309	NEEDLE DRIVING ARM PIN C	ハリクトウ ウツデ ビンC	2
12	07	132-09408	NEEDLE DRIVING PIN A	ハリクトウ ウビビンA	1
13	07	132-09507	NEEDLE DRIVING PIN B	ハリクトウ ウビビンB	1
14	07	132-09606	NEEDLE DRIVING PIN C	ハリクトウ ウビビンC	1
15		131-10602	BUSHING, REAR	ハリクトウ ウツク クワシロメタ	1
16		132-08350	NEEDLE ROD (A) ASM.	ハリネジ (A) クミ	1
17		132-08103	NEEDLE DRIVING LINK WASHER	ハリクトウ ウツクワシロメタ	2
18		EA-9500R01-00	CABLE BAND	ソクセンバンド	1
19		132-09705	NEEDLE ROD BUSHING, UPPER	ハリネジ ウツクメタ	1
20		132-07808	NEEDLE ROD BUSHING CAP SCREW	ハリネジ ウツクメタキャップネジ	1
21		131-10259	NEEDLE CLAMP HOLDER ASM.	ハリトメスタキ	1
22		131-10200	NEEDLE CLAMP HOLDER	ハリトメスタキ	(1)
23		SS-6080720-SP	SCREW 1/8-44 L=7	ヒラネジ 1/8-44 L=7	(1)
24	01	131-10705	NEEDLE THREAD PRESSER GUIDE A	ハリトメネジガイドA	1
25	02	131-10804	NEEDLE THREAD PRESSER GUIDE B	ハリトメネジガイドB	1
26		131-10903	NEEDLE THREAD PRESSER SPRING	ハリトメネジスプリング	1
27		131-11000	NEEDLE THREAD PRESSER PLATE A	ハリトメネジプレートA	1
28	03	132-08806	NEEDLE THREAD GUIDE	ハリトメガイド	1
29	04	132-08905	THREAD GUIDE, 2-NEEDLE	ニネンハハリトメガイド	1
30		132-08707	NEEDLE THREAD GUIDE BASE	ハリトメガイドベース	1
31	02	131-11109	THREAD GUIDE, CHAIN LOOPER	ニネンハハリトメガイド	1
32		SM-4040855-SP	SCREW	ナハネジ	2
33		SS-4110515-SP	SCREW 11/64-40 L=5	ナハネジ 11/64-40 L=5	1
34	05	131-11208	NEEDLE THREAD TAKE-UP LEVER	ハリトメレバー	1
35	04	131-11307	TAKE-UP LEVER, 2-NEEDLE	ニネンハハリトメレバー	1
36	02	131-11406	TAKE-UP LEVER, CHAIN LOOP	ニネンハハリトメレバー	1
37		SS-6090670-TP	SCREW 9/64-40 L=6	ヒラネジ 9/64-40 L=6	2
38	03	131-11505	NEEDLE THREAD BALANCE GUIDE	ハリトメレバーガイド	1
39	04	131-11604	TAKE-UP LEVER GUIDE, 2-NEEDLE	ニネンハハリトメレバーガイド	1
40	02	131-11703	TAKE-UP LEVER GUIDE, CHAIN LOOP	ニネンハハリトメレバーガイド	1
41		SM-4040855-SP	SCREW	ナハネジ	1
42		132-08459	ONCE THROUGH OIL PIPE ASM.	ハリカンリュウパイプ	1
43		132-08509	ONCE THROUGH OIL COVER	ハリカンリュウカバー	(1)
44		CQ-2000000-00	OIL WICK	ウツク	(0.8)
45		236-30007	TUBE	チューブ	(0.39)
46		132-44009	ONCE THROUGH OIL PIPE BUSHING	ハリカンリュウパイプ	(1)
47		132-08608	ONCE THROUGH OIL FELT	ハリカンリュウフェルト	(1)
48		131-42609	PIPE CLAMP	パイプクリップ	(1)
49	07	131-22007	FEED BRANCH CRANK PIN A	オクリフタマタクランクピンA	1
50	07	131-22106	FEED BRANCH CRANK PIN B	オクリフタマタクランクピンB	1
51	07	131-22205	FEED BRANCH CRANK PIN C	オクリフタマタクランクピンC	1
52	07	131-22304	FEED BRANCH CRANK PIN D	オクリフタマタクランクピンD	1
53	06	MDC-270B1100	NEEDLE DCX27 #11	ハリ DCX27 #11	2
54		131-72754	THRUST COLLAR ASM.	ハリクトウ ウツク クラスコラー	(クミ)
55		131-72705	THRUST COLLAR	ハリクトウ ウツク クラスコラー	(1)
56		SS-8660610-TP	SCREW 1/4-40 L=6	トメネジ 1/4-40 L=6	(2)
57		SS-8090530-TP	SCREW 9/64-40 L= 5.0	トメネジ 9/64-40 L=5	2
58		CQ-2020000-00	OIL WICK	ウツク	0.09
59		SS-8090530-TP	SCREW 9/64-40 L= 5.0	トメネジ 9/64-40 L=5	1
60		CQ-2520000-00	OIL WICK	ウツク	0.04
61		SD-0280401-SL	HINGE SCREW D=2.8 H=4	ダボネジ D=2.8 H=4	1
62	05	131-75905	NEEDLE CLAMP, 1-NEEDLE	ハリトメピンハリトメ	1
63	04	122-56905	NEEDLE CLAMP, 2-NEEDLE(BE6)	ニネンハハリトメ (BE6)	1
64	02	122-57002	CHAIN LOOPER NEEDLE CLAMP, DEA	ニネンハハリトメ (DE4)	1
65	05	SS-8080310-TP	SCREW 1/8-44 L=2.8	トメネジ 1/8-44 L=2.8	1
66	05	MDC-270B1100	NEEDLE DCX27 #11	ハリ DCX27 #11	1
67	06	SS-8080310-TP	SCREW 1/8-44 L=2.8	トメネジ 1/8-44 L=2.8	2
68		132-08004	NEEDLE DRIVING LINK	ハリクトウ ウツク	1

NOTE (注記) 01... FOR MO-6704S, MO-6714S MO-6704S, MO-6714S用
02... FOR MO-6716S MO-6716S用
03... FOR MO-6704S, MO-6716S MO-6704S, MO-6716S用
04... FOR MO-6714S MO-6714S用
05... FOR MO-6704S MO-6704S用
06... FOR MO-6714S, MO-6716S MO-6714S, MO-6716S用
07... SELECTIVE PARTS 選択部品

FOR NO.16, ORDER FOR SET ONLY CAN BE ACCEPTED
NO.16は、セットのみの注文になります。

5. FEED MECHANISM COMPONENTS (1)

送り関係 (1)

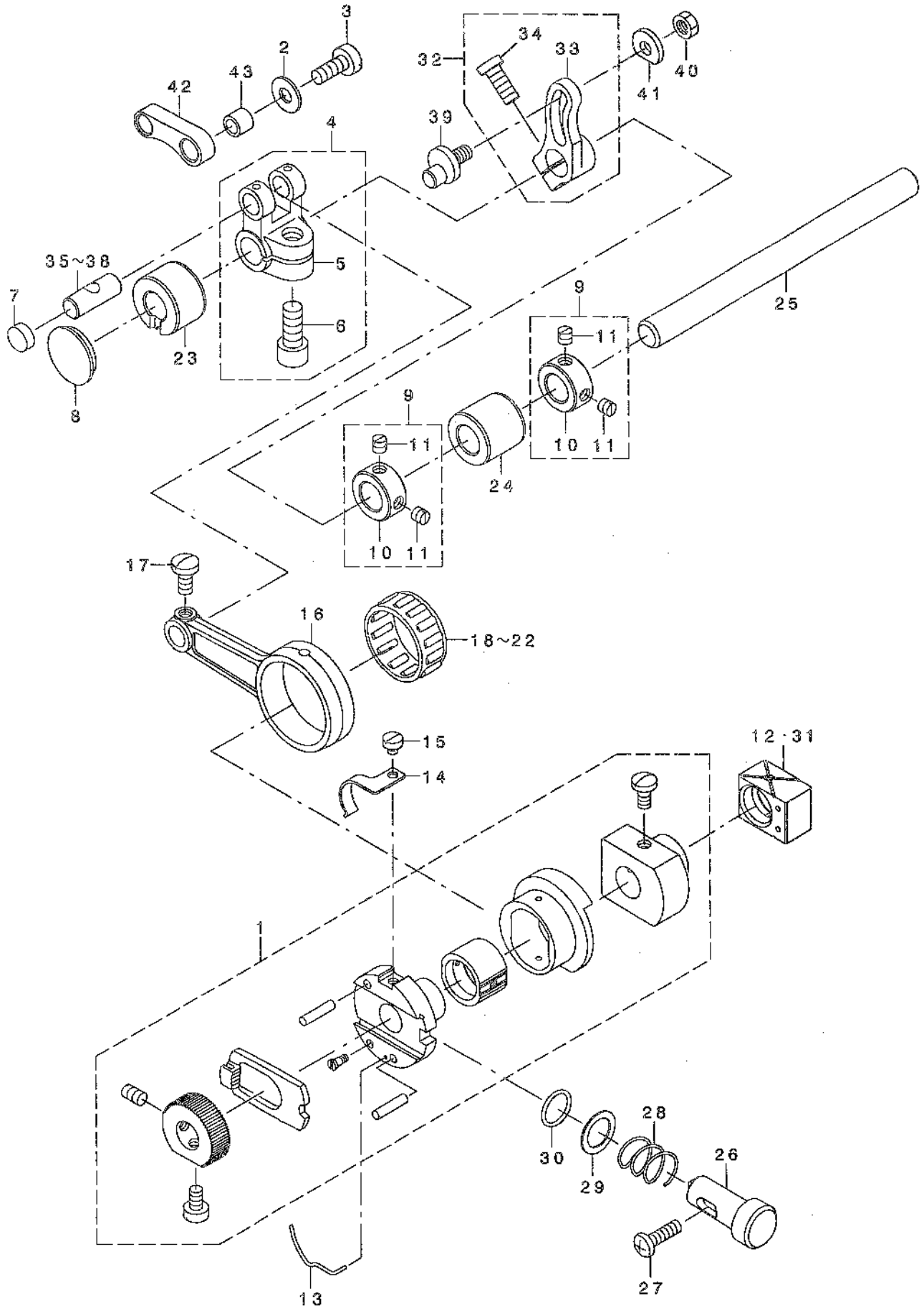

REF. NO	NOTE	PART NO.	DESCRIPTION	キ ヌ メ イ	Qty
1		131-18054	FEED ECCENTRIC BODY ASM.	オクリカムツク タ イクミ	1
2		131-20605	WASHER	ニツ ユウカンロツト サ カ ネ	1
3		SS-6121220-TP	SCREW 3/16-28 L=11.5	ヒラネツ 3/16-28 L=11.5	1
4		131-22452	FEED BRANCH CRANK ASM.	オクリアタマタクランクミ	1
5		131-22403	FEED BRANCH CRANK	オクリアタマタクランク	(1)
6		SM-6061402-TP	SCREW M6 L=14	ロツカクアナネツ M6 L=14	(1)
7		TA-1030402-R0	RUBBER PLUG D=10.3 L=4	トメセン D=10.3 L=4	1
8		TA-2050416-R0	RUBBER PLUG	トメセン	1
9		131-72556	FEED SHAFT THRUST COLLAR ASM.	オクリツ クスラストカテ-(クミ)	2
10		131-72507	FEED SHAFT THRUST COLLAR	オクリツ クスラストカテ	(1)
11		SS-8110410-TP	SCREW 11/64-40 L= 3.5	トメネツ 11/64-40 L=3.5	(2)
12	01	132-17807	SLIDE BLOCK A	シ ヨウケ オクリカクコ マA	1
13		131-22502	RATCHET PAWL SPRING	ラチエツトオチエハ ネ	1
14		131-19300	RATCHET GEAR SPRING	ラチエツトキ ヤハ ネ	1
15		SS-6080320-SP	SCREW 1/8-44 L= 2.5	ヒラネツ 1/8-44 L=2.5	1
16		131-18708	FEED CRANK ROD	オクリクランクロツト	1
17		SS-7110910-TP	SCREW 11/64-40 L= 8.5	マルヒラネツ 11/64-40 L=8.5	1
18	01	121-16604	NEEDLE BEARING	オクリハ アリソク A	1
19	01	121-16703	NEEDLE BEARING B	オクリハ アリソク B	1
20	01	121-16802	NEEDLE BEARING, C.	オクリハ アリソク C	1
21	01	121-16901	NEEDLE BEARING, D.	オクリハ アリソク D	1
22	01	121-17008	NEEDLE BEARING, E.	オクリハ アリソク E	1
23		131-19409	FEED SHAFT METAL, FRONT	オクリツ クマエメタル	1
24		131-19508	FEED SHAFT METAL, REAR	オクリツ クウシロメタル	1
25		131-19607	FEED SHAFT	オクリツ ク	1
26		132-16809	PUSH BUTTON SHAFT	オシホ タンツ ク	1
27		SM-4041455-SN	SCREW M4 L=14	ナハ ネツ M4 L=14	1
28		132-16601	PUSH BUTTON SPRING	オシホ タンハ ネ	1
29		132-16700	PUSH BUTTON SHAFT WASHER	オシホ タンツ クサ	1
30		132-44108	RUBBER RING	Oリング	1
31	01	132-17906	SLIDE BLOCK B	シ ヨウケ オクリカクコ マB	1
32		131-19953	MAIN FEED ARM ASM.	シユオクリウテ クミ	1
33		131-19904	MAIN FEED ARM	シユオクリウテ	(1)
34		SM-6051202-TP	SCREW M5X0.8 L=12	ロツカクアナホ ルト M5X0.8 L=12	(1)
35	01	131-22607	CRANK PIN A	オクリアタマタクランクピ ンA	1
36	01	131-22106	CRANK PIN B	オクリアタマタクランクピ ンB	1
37	01	131-22205	CRANK PIN C	オクリアタマタクランクピ ンC	1
38	01	131-22304	CRANK PIN D	オクリアタマタクランクピ ンD	1
39		131-19706	MAIN FEED ARM PIN	シユオクリウテ ピ ン	1
40		NS-6620320-SP	NUT 3/16-32	ロツカクナツト 3/16-32	1
41		131-20001	WASHER B	シユオクリウテ サ カ ネ(B)	1
42		131-19805	MAIN FEED LINK	シユオクリリンク	1
43		B1620-804-000	PIN COLLAR	シユオクリ ピ ンカテ	1

NOTE (注記) 01...SELECTIVE PARTS 選択部品

FOR NO.1, ORDER FOR SET ONLY CAN BE ACCEPTED
 NO.1は、セットのみの注文になります。

6. FEED MECHANISM COMPONENTS (2)

送り関係 (2)

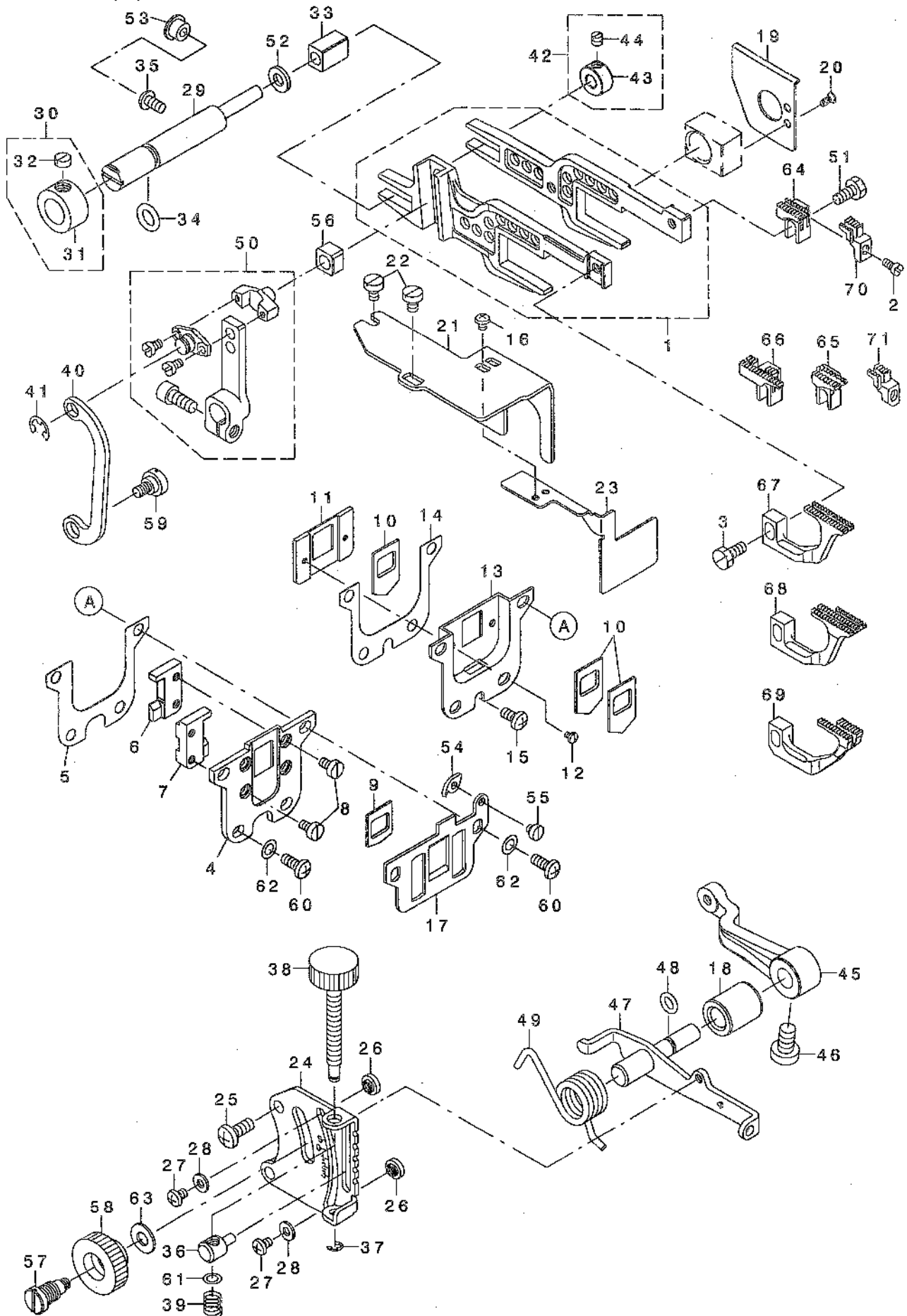

REF. NO	NOTE	PART NO.	DESCRIPTION	品名	Qty
1		132-15157	FEED ROCKER ASM.	ネクリヨウト ウカシタミ	1
2		SS-4080620-TP	SCREW 1/8-44 L=6	ナハネツ 1/8-44 L=6	1
3		SS-9111010-SP	SCREW 11/64-40 L=9.5	ロツカクネ 11/64-40 L=9.5	1
4		132-15306	RUBBER CASE	ホウウツ ノコ ムケース	1
5		132-15405	RUBBER CASE GASKET	ホウウツ ノコ ムケースハ ツキン	1
6		132-15504	FEED BAR SUPPORT , RIGHT	ヨウト ウカシタミエミキ	1
7		132-15603	FEED BAR SUPPORT , LEFT	ヨウト ウカシタミヒダリ	1
8		SS-6090620-TP	SCREW	ヒラネツ	4
9		121-18303	DUST-PROOF RUBBER	ホウウツ ノコ ム	1
10		121-18204	OIL SHIELD RUBBER	アブ ラキリ ム	3
11		132-15702	RUBBER HOLDING PLATE	アブ ラキリ ム アウケイタ	1
12		SS-7060310-SP	SCREW 3/32-56 L=3	マルヒラネツ 3/32-56 L=3	2
13		132-15900	OIL SHIELD CASE	ユホウ ケース	1
14		132-16007	OIL SHIELD CASE GASKET	ユホウ ケースハ ツキン	1
15		SM-4040855-SP	SCREW	ナハネツ	1
16		SM-4030455-SP	SCREW	ナハネツ M3 L=4	2
17		132-15801	THROAT PLATE SUPPORT	ハリイタササエ	1
18		131-22700	ADJUSTING SHAFT METAL	サト ウチヨウセツツ クメタル	1
19		132-16106	OIL SHIELD PLATE	ヨウト ウカシタミ ム	1
20		SS-1060610-SP	SCREW 3/32-56 L=5.5	サラネツ 3/32-56 L=5.5	2
21		132-16205	FEED CAM GIL SHIELD PLATE	ネクリカシタミ ム	1
22		SM-6040600-SP	SCREW M4 L=6	ヒラネツ M4 L=6	2
23		132-16304	OIL SHIELD PLATE	アブ ラキリ ム アウケイタ ム	1
24		131-22809	DIFFERENTIAL FEED GRADUATION	サト ウチヨウセツツ ム	1
25		SM-4051255-SP	SCREW ,M5 L=12.	ナハネツ M5 L=12	2
26		131-21405	ADJUSTING STOPPER	サト ウチヨウセツツ ム	2
27		SS-4090515-SP	SCREW 9/64-40 L=5	ナハネツ 9/64-40 L=5	2
28		WP-0371016-SD	WASHER 3.7X8X1	ヒラネツ カネ 3.7X8X1	2
29		131-20902	SUPPORT SHAFT	ヨウト ウカシタミ	1
30		131-21058	HRUST COLLAR ASM.	ササエツ クイチキムカラ (クミ)	1
31		131-21059	HRUST COLLAR	ササエツ クイチキムカラ	(1)
32		SS-8660330-SP	SCREW 1/4-40 L= 3.0	トメネツ 1/4-40 L=3	(1)
33		131-20803	SLIDE BLOCK	ヨウト ウカシタミエカク ム	1
34		131-70204	RUBBER RING	0リング	1
35		SM-4040855-SP	SCREW	ナハネツ	1
36		132-17708	DIFFERENTIAL FEED BLOCK	サト ウチヨウセツツ ム	1
37		RE-0300000-KO	E-RING 3	Eカ 3	1
38		132-13012	ADJUSTING SCREW	ヒラネツ	1
39		131-23302	DIFFERENTIAL FEED SCREW SPRING	サト ウチヨウセツツ ム	1
40		131-21306	ADJUSTING LINK	サト ウチヨウセツツ ム	1
41		RE-0500000-KO	E-RING 5	Eカ 5	1
42		131-21256	SUPPORT SHAFT COLLAR ASM.	ヨウト ウカシタミ ム	1
43		131-21207	SUPPORT SHAFT COLLAR	ヨウト ウカシタミ ム	(1)
44		SS-8110410-TP	SCREW 11/64-40 L= 3.5	トメネツ 11/64-40 L=3.5	(1)
45		131-21900	DIFFERENTIAL FEED ROCKER	サト ウチヨウセツツ ム	1
46		SS-6661110-SP	SCREW 1/4-40 L=11	ヒラネツ 1/4-40 L=11	1
47		132-17351	ROCKER SHAFT ASM.	サト ウチヨウセツツ ム	1
48		131-70501	RUBBER RING	0リング	1
49		131-21603	ADJUSTING LEVER SPRING	サト ウチヨウセツツ ム	1
50		132-18052	DIFFERENTIAL FEED ARM ASM.	フクネクリ ム	1
51		SS-9111050-SP	SCREW 11/64-40 L=9.5	ロツカクネ 11/64-40 L=9.5	1
52		131-21108	WASHER	ヨウト ウカシタミ ム	1
53		TA-0800504-RO	PLUG D=8 L=4.5	トメセン D=8X4.5	1
54		132-00902	FEED MECHANISM COVER PRESSER	ネクリフタササエ	1
55		SS-6080340-SP	SCREW 1/8-44 L=2.9	ヒラネツ 1/8-44 L=2.9	1
56		132-18102	SLIDE BLOCK	フクネクリ ム	1
57		132-17401	DIFFERENTIAL FEED HINGE SCREW	サト ウチヨウセツツ ム	1
58		132-17500	DIFFERENTIAL FEED LOCK NUT	サト ウチヨウセツツ ム	1
59		SD-0720271-SP	HINGE SCREW D=7.2 H=2.7	ダネツ D=7.2 H=2.7	1
60		SM-4041055-SP	SCREW M4 L=10	ナハネツ M4 L=10	4
61		WP-0460556-SD	WASHER 4.6X7.5X0.5	ヒラネツ カネ 4.6X7.5X0.5	1
62		WP-0480856-SD	WASHER 4.8X8.4X0.8	ヒラネツ カネ 4.8X8.4X0.8	4
63		WP-0621016-SD	WASHER 6.2X13X1	ヒラネツ カネ 6.2X13X1	1
64	03	131-91606	MAIN FEED DOG	シユネクリハ	1
65	04	119-49807	MAIN FEED DOG (F-25)	シユネクリハ (F-25)	1
66	02	131-92408	MAIN FEED DOG	シユネクリハ	1
67	03	131-92802	DIFFERENTIAL FEED DOG	フクネクリハ	1
68	04	131-93206	DIFFERENTIAL FEED DOG	フクネクリハ	1
69	02	131-93602	DIFFERENTIAL FEED DOG	フクネクリハ	1
70	01	131-91309	AUXILIARY FEED DOG	ホウ ヨネクリハ	1
71	02	131-91408	AUXILIARY FEED DOG	ホウ ヨネクリハ	1

NOTE (注記)

01... FOR MO-6704S, MO-6714S MO-6704S, MO-6714S用
02... FOR MO-6716S MO-6716S用
03... FOR MO-6704S MO-6704S用
04... FOR MO-6714S MO-6714S用

FOR NO.1, 50, ORDER FOR SET ONLY CAN BE ACCEPTED
NO.1, 50は、セットのみの注文になります。

7. UPPER & LOWER LOOPER COMPONENTS

上ルーパ、下ルーパ関係

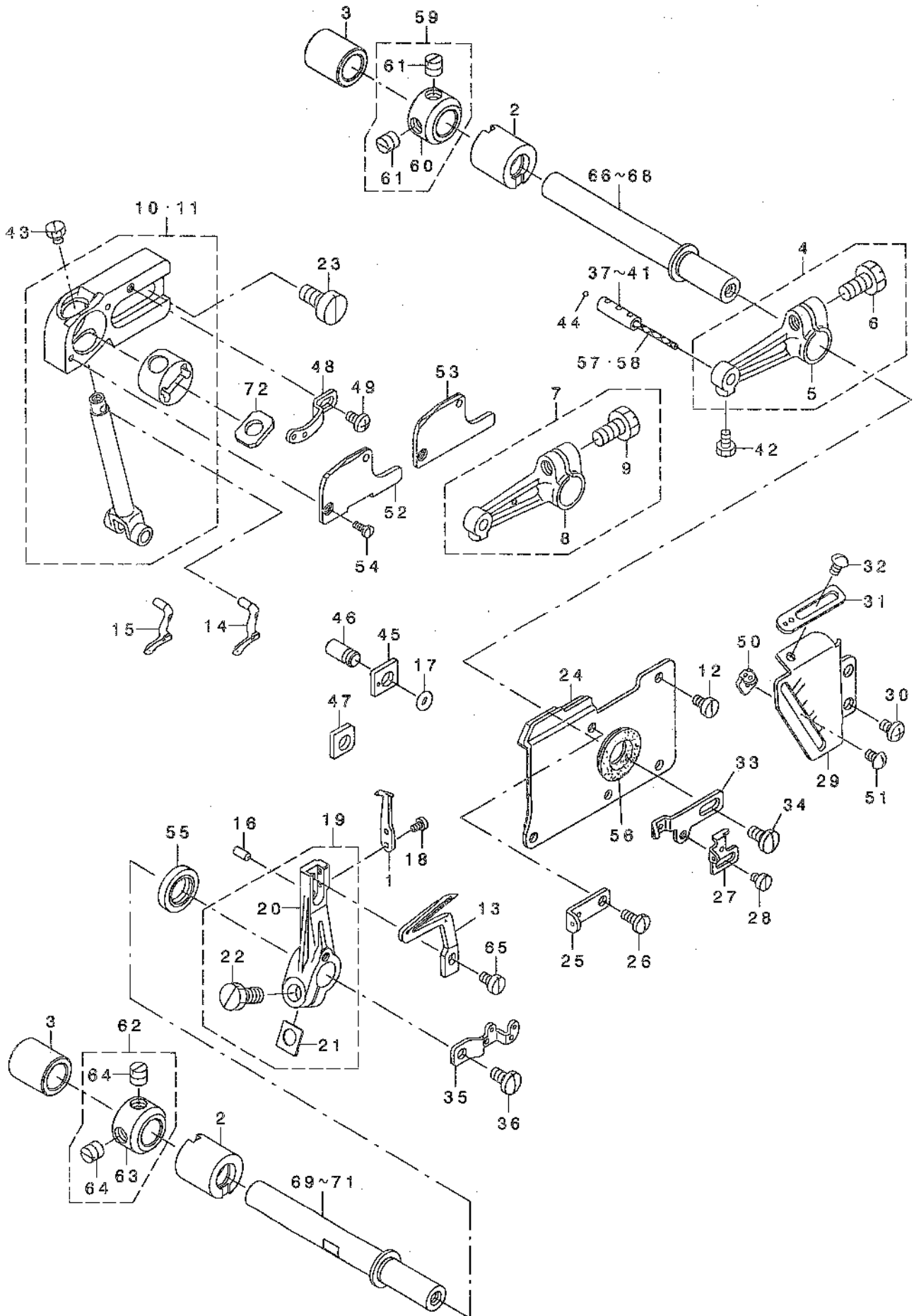

REF. NO	NOTE	PART NO.	DESCRIPTION	品名	Qty
1		118-90001	TRAVELING NEEDLE GUARD	針-ハリガード	1
2		132-22609	LOOPER SHAFT FRONT BUSHING	ル-ハ-シャフトクマエシヤ	2
3		132-22708	LOOPER SHAFT REAR BUSHING	ル-ハ-シャフトウシヤ	2
4	01	131-31057	UPPER LOOPER ARM A ASM.	ウツル-ハ-ウツアタミ	1
5		131-31008	UPPER LOOPER ARM A	ウツル-ハ-ウツA	(1)
6		SS-9151210-TP	SCREW 15/64-28 L=11.8	ロツカクネ 針 15/64-28	(1)
7	02	131-31156	UPPER LOOPER ARM B ASM.	ウツル-ハ-ウツBタミ	1
8		131-31107	UPPER LOOPER ARM B	ウツル-ハ-ウツB	(1)
9		SS-9151210-TP	SCREW 15/64-28 L=11.8	ロツカクネ 針 15/64-28	(1)
10	01	400-15837	GUIDE SUPPORT ASM.	ウツル-ハ-ガイイトササエタミ	1
11	02	400-16841	GUIDE SUPPORT B ASM	ウツル-ハ-ガイイトササエタミ	1
12		SS-6090630-TP	SCREW 9/64-40 L=6	ヒラネツ 9/64-40 L=6	4
13		119-99307	LOWER LOOPER	ウツル-ハ-	1
14	01	118-88104	UPPER LOOPER	ウツル-ハ-	1
15	02	121-76004	UPPER LOOPER	ウツル-ハ-	1
16		PS-0300062-KH	SPRING PIN 3X6	スプリングピン 3X6	1
17		131-70600	RUBBER RING	ロツク	1
18		SS-6060440-TP	SCREW 3/32-56 L=3.5	ヒラネツ	2
19		131-32550	LOWER LOOPER SUPPORT ARM ASM.	ウツル-ハ-ウツウツタミ	1
20		131-32501	LOWER LOOPER SUPPORT ARM	ウツル-ハ-ウツウツ	(1)
21		131-29309	WASHER	ウツウツシヤシヤシヤ	(1)
22		SS-9151210-TP	SCREW 15/64-28 L=11.8	ロツカクネ 針 15/64-28	(1)
23		SM-6061200-SP	SCREW M6 L=12	ヒラネツ M6 L=12	2
24		121-23659	OIL SHIELD PLATE ASM.	ル-ハ-ガードイットコホウノタミ	1
25		123-40600	UPPER LOOPER THREAD GUIDE	ウツル-ハ-イトアソナイ(ナカ)	1
26		SS-7090850-SP	SCREW 9/64-40 L=8	マキヒラネツ 9/64-40 L=8	1
27		123-40709	LOWER LOOPER THREAD TAKE-UP	ウツル-ハ-テツヒツ	1
28		SS-6080410-SP	SCREW 1/8-44 L=4	ヒラネツ 1/8-44 L=4	1
29		122-22401	LOOPER THREAD TAKE-UP COVER	ル-ハ-テツヒツカバ-	1
30		SM-4040655-SP	SCREW M4 L=6	ナカコネツ M4 L=6	2
31		123-40303	THREAD GUIDE, RIGHT	ウツル-ハ-イトアソナイミキ	1
32		SS-3090610-SP	SCREW 9/64-40 L=6	マキヒラネツ 9/64-40 L=6	1
33		123-40402	THREAD TAKE-UP, RIGHT	ウツル-ハ-テツヒツミキ	1
34		SS-7110840-SP	SCREW 11/64-40 L=7.8	マキヒラネツ 11/64-40 L=7.8	1
35		123-40907	LOWER THREAD TAKE-UP, LEFT	ル-ハ-テツヒツ(ヒタリ)	1
36		SS-7110840-SP	SCREW 11/64-40 L=7.8	マキヒラネツ 11/64-40 L=7.8	1
37	03	131-31206	UPPER LOOPER HOLDER PIN A	ウツル-ハ-ダキピン(A)	1
38	03	131-31305	UPPER LOOPER HOLDER PIN B	ウツル-ハ-ダキピン(B)	1
39	03	131-31404	UPPER LOOPER HOLDER PIN C	ウツル-ハ-ダキピン(C)	1
40	03	131-31503	UPPER LOOPER HOLDER PIN D	ウツル-ハ-ダキピン(D)	1
41	03	131-31602	UPPER LOOPER HOLDER PIN E	ウツル-ハ-ダキピン(E)	1
42		SS-9090610-TP	SCREW 9/64-40 L=5.5	ロツカクネ 針 9/64-40 L=5.5	1
43		SS-9090410-TP	SCREW	ロツカクネ 針	1
44		131-31701	OIL WICK STOPPER BALL	ユツノメダマ	1
45	04	131-31908	GUIDE SUPPORT GAUGE	ウツル-ハ-ガイイトササエタ-	1
46		131-31800	GAUGE FIXING PIN	ゲニツコサヒツ	1
47	05	131-32006	GUIDE SUPPORT GAUGE	ウツル-ハ-ガイイトササエタ-	1
48		123-40501	THREAD GUIDE, UPPER	ウツル-ハ-イトアソナイ(ウエ)	1
49		SS-4090615-SP	SCREW 9/64-40 L=6	ナカコネツ 9/64-40 L=6	1
50		123-40808	THREAD GUIDE	ウツル-ハ-イトアソナイ	1
51		SS-3090610-SP	SCREW 9/64-40 L=6	マキヒラネツ 9/64-40 L=6	1
52	01	132-22203	UPPER LOOPER GAUGE COVER	ウツル-ハ-ガイイトフタ	1
53	02	132-22302	UPPER LOOPER GAUGE COVER B	ウツル-ハ-ガイイトフタ(B)	1
54		SS-7060610-SP	SCREW 3/32-56 L= 5.5	マキヒラネツ 3/32-56 L=5.5	2
55		400-10804	OIL SEAL RING	オイルシヤル	1
56		131-32709	UPPER LOOPER SHAFT RUBBER RING	ウツル-ハ-シャフトクマシヤ	1
57		CQ-2000000-00	OIL WICK	ユツ	0.04
58		CQ-2020000-00	OIL WICK	ユツ	0.04
59	04	131-72853	THRUST COLLAR ASM.	ル-ハ-ツクスタストカラー(タミ)	2
60		131-72804	THRUST COLLAR	ル-ハ-ツクスタストカラー	(1)
61		SS-8660610-TP	SCREW 1/4-40 L=6	トメネツ 1/4-40 L=6	(2)
62	05	131-72853	THRUST COLLAR ASM.	ル-ハ-ツクスタストカラー(タミ)	1
63		131-72804	THRUST COLLAR	ル-ハ-ツクスタストカラー	(1)
64		SS-8660610-TP	SCREW 1/4-40 L=6	トメネツ 1/4-40 L=6	(2)
65		SS-6090620-TP	SCREW	ヒラネツ	1
66	03	132-21403	UPPER LOOPER GUIDE A	ウツル-ハ-ツクA	1
67	03	132-21502	UPPER LOOPER GUIDE B	ウツル-ハ-ツクB	1
68	03	132-21601	UPPER LOOPER GUIDE C	ウツル-ハ-ツクC	1
69	03	132-21700	UPPER LOOPER GUIDE A	ウツル-ハ-ツクA	1
70	03	132-21809	UPPER LOOPER GUIDE B	ウツル-ハ-ツクB	1
71	03	132-21908	UPPER LOOPER GUIDE C	ウツル-ハ-ツクC	1
72		400-11234	DUST SEALING FELT	ウツル-ハ-ガイイトフェルト	1

NOTE (注記)

01... FOR MO-6704S, MO-6716S
02... FOR MO-6714S
03... SELECTIVE PARTS
04... FOR MO-6704S, MO-6714S
05... FOR MO-6716S

MO-6704S, MO-6716S
MO-6714S
選択部品
MO-6704S, MO-6714S
MO-6716S

FOR NO. 10, 11, ORDER FOR SET ONLY CAN BE ACCEPTED
NO. 10, 11は、セットのみの注文になります。

8. CHAIN LOOPER COMPONENTS (FOR MO-6716S)

二重環ルーバ関係(MO-6716S用)

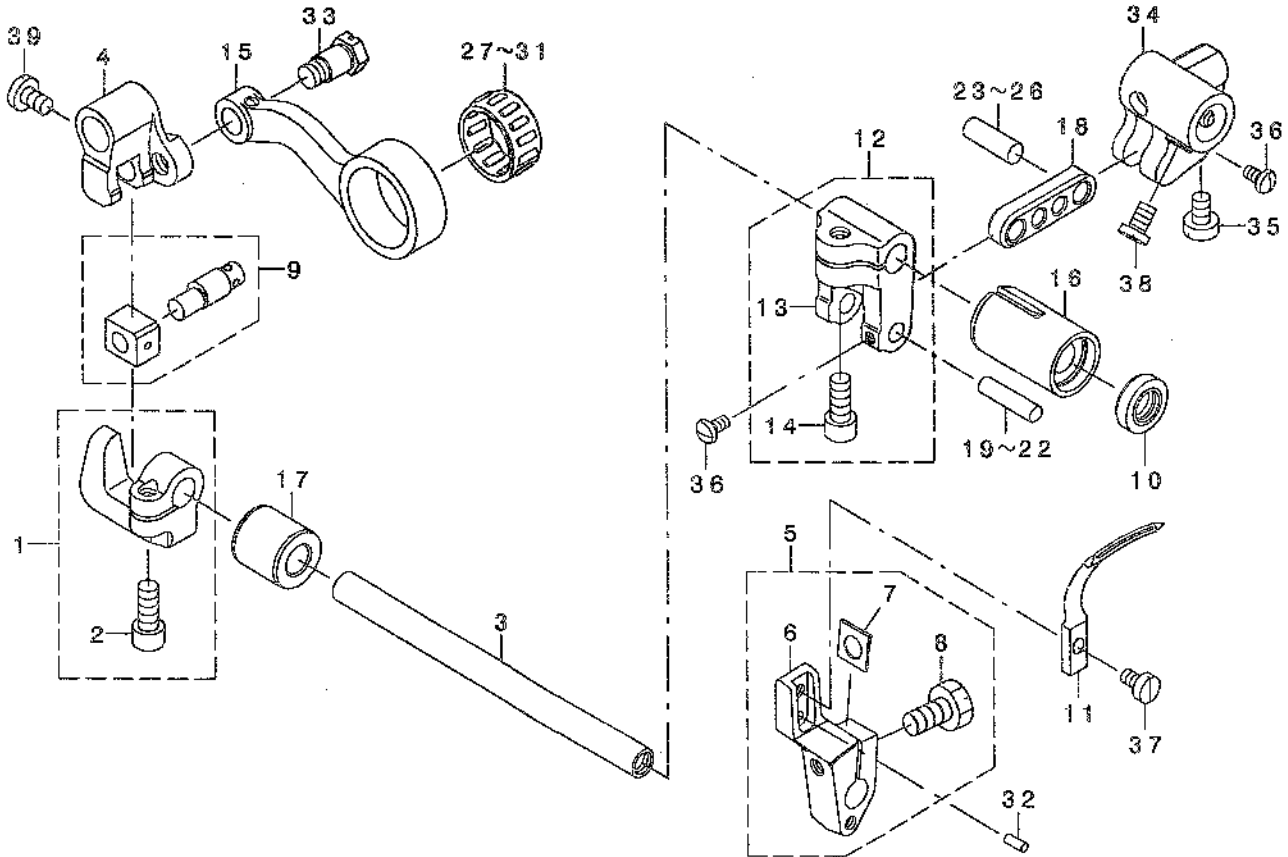

REF. NO	NOTE	PART NO.	DESCRIPTION	キ ャ ッ プ	Qty
1		131-29853	BRACKET	ニブ ムカヨクコマダ キグミ	1
2		SM-6051202-TP	SCREW M5X0.8 L=12	ワザカクナキ 糸 M5X0.8 L=12	(1)
3		131-26909	CHAIN LOOPER SHAFT	ニブ ムカヨクノク	1
4		131-26008	FRONT-AND-REAR ARM	ニブ ムカヨクノクノクノク	1
5		131-29952	CHAIN LOOPER DRIVING ARM ASM.	ニブ ムカヨクノクノクノク	1
6		131-29903	CHAIN LOOPER DRIVING ARM	ニブ ムカヨクノクノクノク	(1)
7		131-29309	WASHER	ワザ カク ノクノクノク	(1)
8		SS-9151210-TP	SCREW 15/64-28 L=11.8	ワザカクナキ 糸 15/64-28	(1)
9		131-26354	SLIDE BLOCK PIN ASM.	ニブ ムカヨクノクノクノク	1
10		400-10805	OIL SEAL RING	オイシヤール	1
11		121-20705	CHAIN LOOPER	ニブ ムカヨクノクノク	1
12		131-25850	CHAIN LOOPER DRIVING ARM ASM.	ニブ ムカヨクノクノクノク	1
13		131-25901	CHAIN LOOPER DRIVING ARM	ニブ ムカヨクノクノクノク	(1)
14		SM-6051202-TP	SCREW M5X0.8 L=12	ワザカクナキ 糸 M5X0.8 L=12	(1)
15		132-20009	CHAIN LOOPER ROD	ニブ ムカヨクノクノク	1
16		131-28103	BUSHING, FRONT	ニブ ムカヨクノクノクノク	1
17		131-27006	BUSHING, REAR	ニブ ムカヨクノクノクノク	1
18		131-27105	CHAIN LOOPER SHAFT DRIV. LINK	ニブ ムカヨクノクノクノク	1
19	01	131-26503	PIN, LONG A	ニブ ムカヨクノクノクノク(チヨウ)A	1
20	01	131-26602	PIN, LONG B	ニブ ムカヨクノクノクノク(チヨウ)B	1
21	01	131-26701	PIN, LONG C	ニブ ムカヨクノクノクノク(チヨウ)C	1
22	01	131-26800	PIN, LONG D	ニブ ムカヨクノクノクノク(チヨウ)D	1
23	01	131-27204	PIN, SHORT A	ニブ ムカヨクノクノクノク(チヨウ)A	1
24	01	131-27303	PIN, SHORT B	ニブ ムカヨクノクノクノク(チヨウ)B	1
25	01	131-27402	PIN, SHORT C	ニブ ムカヨクノクノクノク(チヨウ)C	1
26	01	131-27501	PIN, SHORT D	ニブ ムカヨクノクノクノク(チヨウ)D	1
27	01	B2119-816-A00	BEARING A	ニブ ムカヨクノクノクノク A	1
28	01	B2119-816-B00	BEARING B	ニブ ムカヨクノクノクノク B	1
29	01	B2119-816-C00	BEARING C	ニブ ムカヨクノクノクノク C	1
30	01	B2119-816-D00	BEARING D	ニブ ムカヨクノクノクノク D	1
31	01	B2119-816-E00	BEARING E	ニブ ムカヨクノクノクノク E	1
32		PS-0250062-KH	SPRING PIN 2.5X6	スプリング ピン 2.5X6	1
33		SD-0720803-TH	STEP-SCREW D=7,24 H=8	ダンネツ	1
34		121-21612	DRIVING BALL ARM BRACKET	ワザカクナキ	1
35		SS-6110710-TP	SCREW 11/64-40 L= 6.5	ワザカクナキ 11/64-40 L=6.5	1
36		SS-4080620-TP	SCREW 1/8-44 L=6	ワザカクナキ 1/8-44 L=6	2
37		SS-6090620-TP	SCREW	ワザカクナキ	1
38		SS-6110710-TP	SCREW 11/64-40 L= 6.5	ワザカクナキ 11/64-40 L=6.5	2
39		SS-7110720-TP	SCREW 11/64-40 L=7	ワザカクナキ 11/64-40 L=7	1

NOTE (注記)

01... SELECTIVE PARTS

選択部品

FOR NO.9,ORDER FOR SET ONLY CAN BE ACCEPTED
NO.9は、セットのみの注文になります。

9. PRESSER FOOT COMPONENTS (1)

押さえ関係 (1)

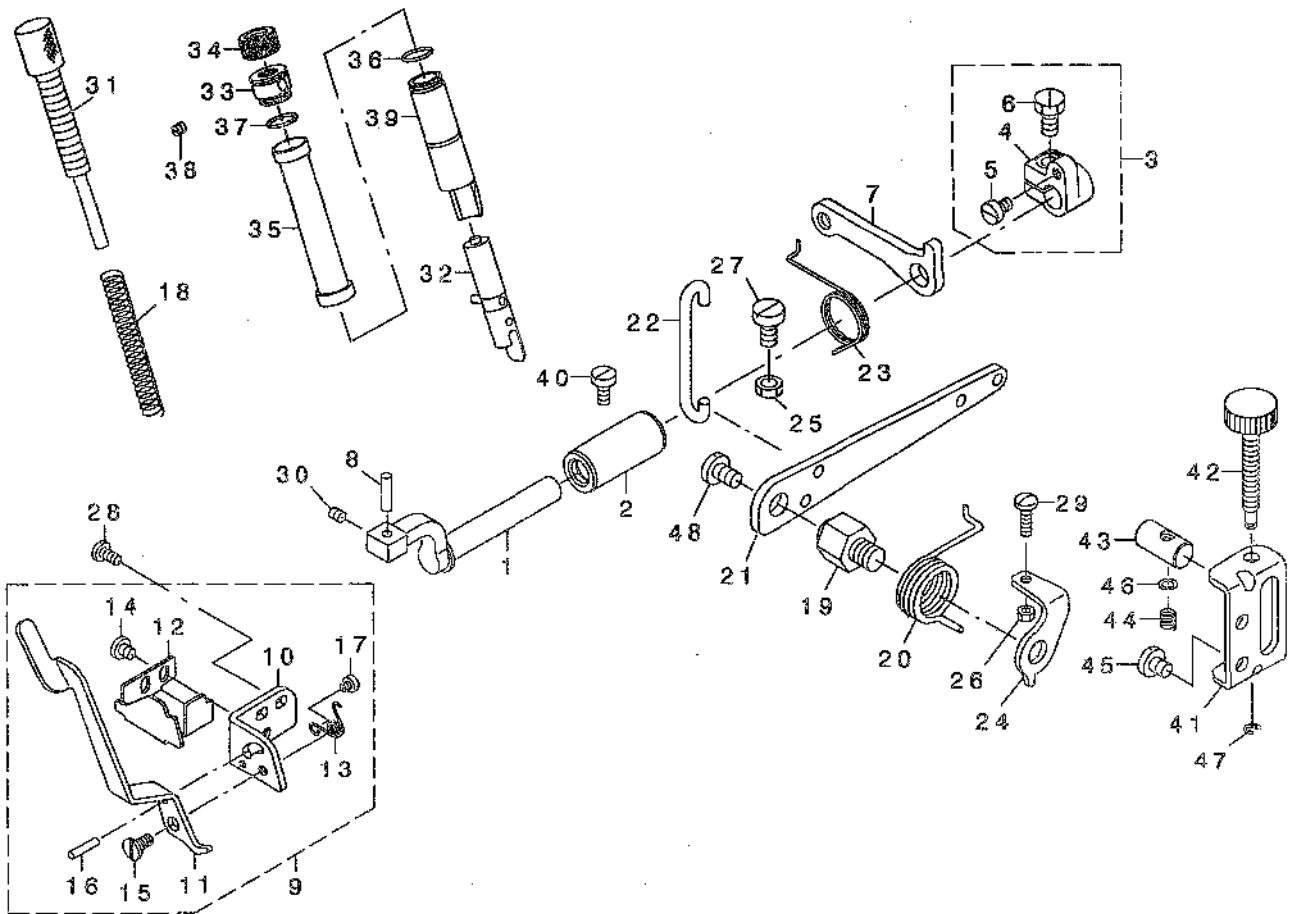

REF. NO	NOTE	PART NO.	DESCRIPTION	品名	Qty
1		131-15001	PRESSER FOOT SHAFT	押し足シャフト	1
2		131-15100	PRESSER FOOT SHAFT BUSHING	押し足シャフトクマシ	1
3		131-15258	THRUST ARM ASM.	押し足クマシストロウダ	1
4		131-15209	THRUST ARM	押し足クマシストロウダ	(1)
5		SS-6110710-TP	SCREW 11/64-40 L=6.5	ビス 11/64-40 L=6.5	(1)
6		SS-9151210-TP	SCREW 15/64-28 L=11.8	ワッシャー 15/64-28	(1)
7		131-16801	LIFTING ARM	押し足クマシ	1
8		131-15407	PRESSER FOOT ARM HINGE SHAFT	押し足クマシヒンジシャフト	1
9		131-15753	PRESSER LIFTING LEVER BASE ASM	押し足クマシレバースタンプ	1
10		131-15803	PRESSER LIFTING LEVER BASE	押し足クマシレバースタンプ	(1)
11		131-15902	PRESSER LIFTING LEVER	押し足クマシレバースタンプ	(1)
12		131-16009	PRESSER ARM STOPPER	押し足クマシストップ	(1)
13		131-16108	PRESSER FOOT LIFTING SPRING	押し足クマシバネ	(1)
14		SS-7110510-SP	SCREW 11/64-40 L=5	ビス 11/64-40 L=5	(2)
15		SD-0640241-SP	HINGE SCREW D=6.35 H=2.4	クマシ D=6.35 H=2.4	(1)
16		PS-0300142-KH	SPRING PIN D.3 X 14	スプリングピン D.3 X 14	(1)
17		SS-6080340-SP	SCREW 1/8-44 L=2.9	ビス 1/8-44 L=2.9	(1)
18		131-16207	PRESSER FOOT SPRING	押し足バネ	1
19		131-17007	PRESSER LIFTING LEVER SCREW	押し足クマシレバースタンプ	1
20		131-16306	PRESSER LIFTING LEVER SPRING	押し足クマシレバースタンプ	1
21		131-16900	PRESSER LIFTING LEVER	押し足クマシレバースタンプ	1
22		131-16405	PRESSER LIFTING HOOK	押し足クマシフック	1
23		131-16504	LIFTING LEVER ARM SPRING	押し足クマシクマシバネ	1
24		131-16603	PRESSER LIFTING LEVER SPRING	押し足クマシストップ	1
25		NH-6060003-SC	NUT M6	ワッシャー M6	1
26		NS-6110420-SP	NUT 11/64-40	ワッシャー M6 11/64-40	1
27		SH-6061200-SP	SCREW M6 L=12	ビス M6 L=12	1
28		SS-7110840-SP	SCREW 11/64-40 L=7.8	ビス 11/64-40 L=7.8	2
29		SS-7111410-TP	SCREW 11/64-40 L=14	ビス 11/64-40 L=14	1
30		SS-8110520-TP	SCREW 11/64-40 L=4.5	ビス 11/64-40 L=4.5	1
31		132-12800	PRESSER REGULATOR SCREW	押し足クマシレバースタンプ	1
32		131-15654	PRESSER BAR ASM.	押し足クマシ	1
33		122-88700	PRESSER REGULATOR SCREW WASHER	押し足クマシレバースタンプ	1
34		131-17106	PRESSER REGULATOR NUT	押し足クマシレバースタンプ	1
35		132-12709	PRESSER BAR COVER	押し足クマシ	1
36		131-70402	RUBBER RING	ゴムリング	2
37		131-70402	RUBBER RING	ゴムリング	1
38		SH-8040402-TP	SCREW M4X0.7 L=4	ビス M4X0.7 L=4	1
39		132-12501	PRESSER BAR BUSHING	押し足クマシ	1
40		SS-6121020-SP	SCREW 3/16-28 L=9.5	ビス 3/16-28 L=9.5	1
41		132-12808	ADJUSTING BASE	押し足クマシレバースタンプ	1
42		132-13012	ADJUSTING SCREW	押し足クマシレバースタンプ	1
43		132-12915	ADJUSTING BLOCK	押し足クマシレバースタンプ	1
44		131-23302	ADJUSTING SPRING	押し足クマシレバースタンプ	1
45		SS-7150740-SP	SCREW 15/64-28 L=7	ビス 15/64-28 L=7	2
46		WP-0460556-SP	WASHER 4.6X7.6X0.5	ワッシャー 4.6X7.6X0.5	1
47		RE-0300000-K0	E-RING 3	Eリング 3	1
48		SS-7161040-SP	SCREW 1/4-24 L=9.5	ビス 1/4-24 L=9.5	1

10. PRESSER FOOT COMPONENTS (2)

押さえ関係 (2)

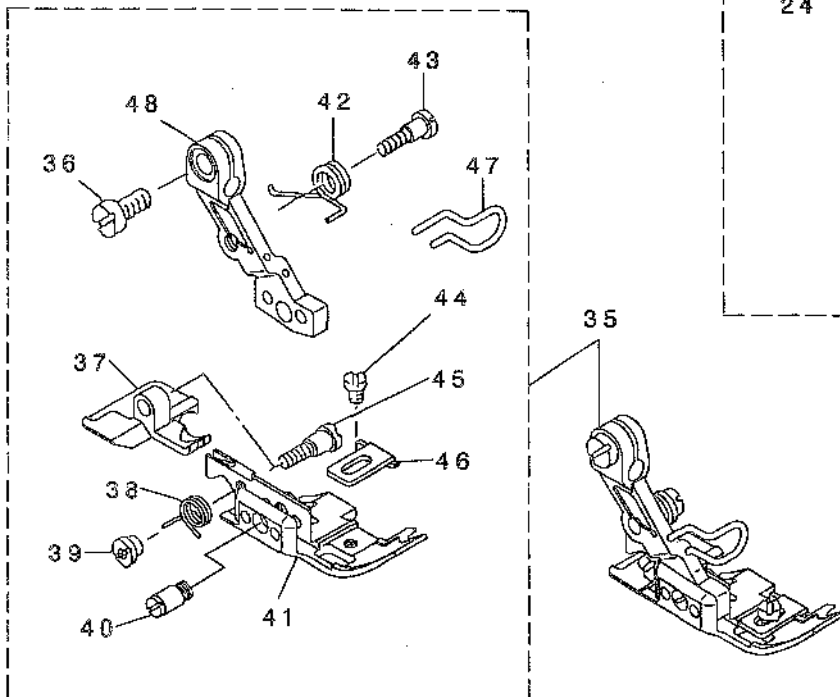
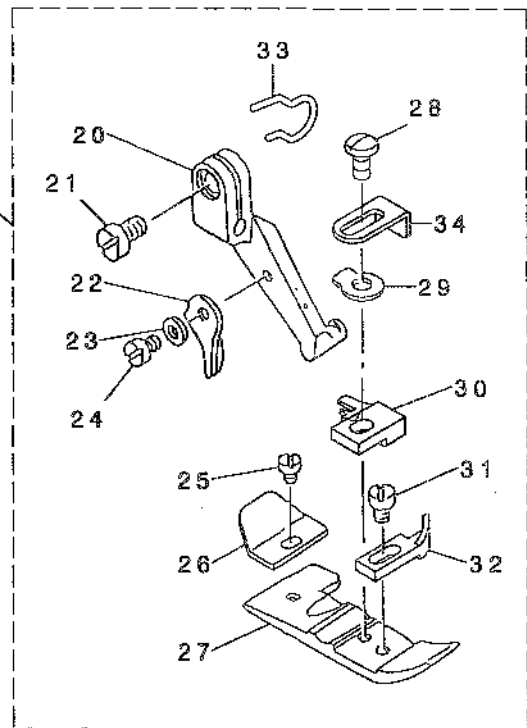
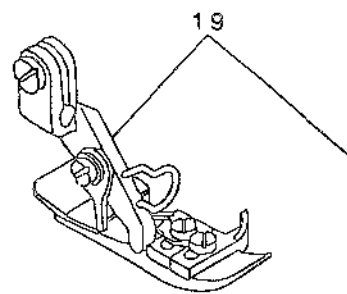
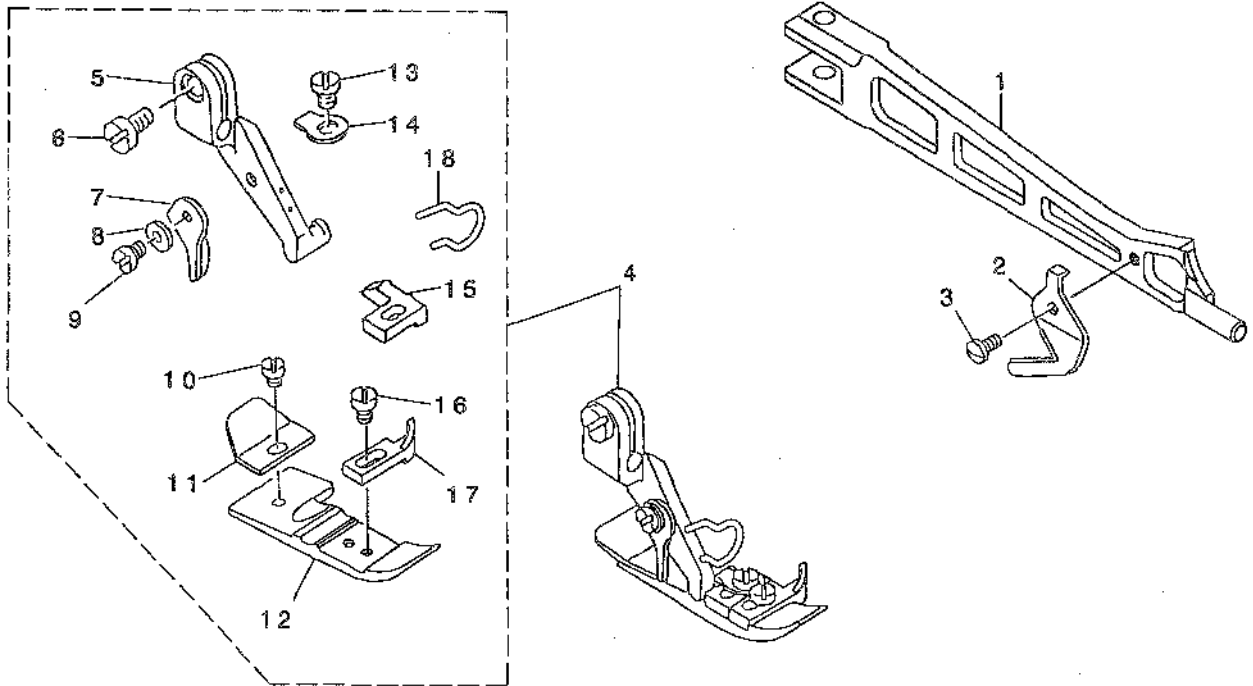

REF. NO	NOTE	PART NO.	DESCRIPTION	ヒソメイ	Qty
1		122-53829	PRESSER FOOT ARM	オサエウテ	1
2		131-16702	THREAD TRIMMER	イトキリハ	1
3		SS-7060510-SP	SCREW 3/32-56 L=4.8	マルヒラネジ 3/32-56 L=4.8	1
4	01	118-76166	PRESSER FOOT ASM.	オサエ クミ	1
5		118-72009	PRESSER FOOT HINGE	オサエヒンジ	(1)
6		SS-6090670-TP	SCREW 9/64-40 L=6	ヒラネジ 9/64-40 L=6	(1)
7		B1530-804-000	STOPPER	オサエ ストツハ	(1)
8		WP-0250516-SD	WASHER 2.5X6X0.5	ヒラサカネ 2.5X6X0.5	(1)
9		SS-7060610-SP	SCREW 3/32-56 L= 5.5	マルヒラネジ 3/32-56 L=5.5	(1)
10		SS-6060210-SP	SCREW 3/32-56 L= 1.9	ヒラネジ 3/32-56 L=1.9	(1)
11		B1511-814-000	REAR PRESSER FOOT	カラカントメ	(1)
12		B1507-804-C00	PRESSER FOOT	オサエ	(1)
13		SS-7080520-SP	SCREW 1/8-44 L=4.9	マルヒラネジ 1/8-44 L=4.9	(1)
14		B1508-804-00B	SPRING	オサエ トリツケハネ	(1)
15		B1509-804-C00	STITCH TONGUE	イトスハ リタイ	(1)
16		SS-6060440-TP	SCREW 3/32-56 L=3.5	ヒラネジ	(1)
17		B1510-814-000	CURL GUARD	カールトメ	(1)
18		131-78306	FINGER GUIDE	エビカト	(1)
19	02	118-76869	PRESSER FOOT ASM.	オサエ クミ	1
20		118-72009	PRESSER FOOT HINGE	オサエヒンジ	(1)
21		SS-6090670-TP	SCREW 9/64-40 L=6	ヒラネジ 9/64-40 L=6	(1)
22		B1530-804-000	STOPPER	オサエ ストツハ	(1)
23		WP-0250516-SD	WASHER 2.5X6X0.5	ヒラサカネ 2.5X6X0.5	(1)
24		SS-7060610-SP	SCREW 3/32-56 L= 5.5	マルヒラネジ 3/32-56 L=5.5	(1)
25		SS-6060210-SP	SCREW 3/32-56 L= 1.9	ヒラネジ 3/32-56 L=1.9	(1)
26		B1511-814-000	REAR PRESSER FOOT	カラカントメ	(1)
27		B1507-814-00P	PRESSER FOOT	オサエ	(1)
28	*	SS-4080620-TP	SCREW 1/8-44 L=6	ナハネジ 1/8-44 L=6	(1)
29		B1508-804-00B	SPRING	オサエ トリツケハネ	(1)
30		B1509-814-00P	STITCH TONGUE	イトスハ リタイ	(1)
31		SS-6060440-TP	SCREW 3/32-56 L=3.5	ヒラネジ	(1)
32		B1510-814-000	CURL GUARD	カールトメ	(1)
33		131-78306	FINGER GUIDE	エビカト	(1)
34	*	400-30533	PRESSER FOOT AUXILIARY PLATE	オサエホシヨイタ	(1)
35	03	121-53763	PRESSER FOOT ASM.	ジユウオサエクツコウ(エビカト)ツキ	1
36		SS-6090670-TP	SCREW 9/64-40 L=6	ヒラネジ 9/64-40 L=6	(1)
37		121-64802	REAR PRESSER FOOT	ウツロ オサエ	(1)
38		121-67805	SPRING, FOR REAR PRESSER FOOT	ニダノオサエハネ	(1)
39		B1513-816-000	NUT, FOR REAR PRESSER FOOT	2ダノオサエ ヒンジネジ ナツト	(1)
40		121-67409	HINGE PIN	ジユウオサエ ヒンジピン	(1)
41		121-62202	PRESSER FOOT	ジユウオサエ	(1)
42		121-67607	PRESSER FOOT ARM SPRING	オサエウテハネ	(1)
43		121-67508	HINGE SCREW	ニダノオサエ ヒンジネジ	(1)
44		SS-6060340-SP	SCREW 3/32-56 L= 2.5	ヒラネジ 3/32-56 L=2.5	(1)
45		B1514-816-000	SCREW	オサエウテハネ トリツケネジ	(1)
46		121-67706	PRESSER FOOT	ヌノオサエ	(1)
47		131-78405	FINGER GUIDE	エビカト	(1)
48		121-56907	PRESSER FOOT HINGE	ジユウオサエ ヒンジ	(1)
	NOTE (注記)	01....FOR MO-6704S		MO-6704S用	
		02....FOR MO-6714S		MO-6714S用	
		03....FOR MO-6716S		MO-6716S用	

REF. NO.	NOTE	PART NO.	DESCRIPTION	品名	Qty
1		132-25008	CENTER THREAD GUIDE	チュウカンイトアンナイ	1
2		131-37559	THREAD TENSION SPRING COMPL.	イトチュウツハネケツゴウ(アカ)	1
3	01	131-38359	THREAD TENSION SPRING COMPL.	イトチュウツハネケツゴウ(キ)	1
4		131-38656	THREAD TENSION SPRING COMPL.	イトチュウツハネケツゴウ(アオ)	1
5		131-37807	THREAD TENSION SPRING, RED	イトチュウツハネ(アカ)	(1)
6		131-38508	THREAD TENSION SPRING, YELLOW	イトチュウツハネ(キ)	(1)
7		131-38805	THREAD TENSION SPRING, BLUE	イトチュウツハネ(アオ)	(1)
8		131-37708	THREAD TENSION KNOB, RED	イトチュウツマミ(アカ)	(1)
9		131-38409	THREAD TENSION KNOB, YELLOW	イトチュウツマミ(キ)	(1)
10		131-38706	THREAD TENSION KNOB, BLUE	イトチュウツマミ(アオ)	(1)
11		131-38904	THREAD TENSION BAR	イトチュウツハネウ	(1)
12		131-37609	THREAD TENSION DISK PRESSER	イトチュウツサラネサエ	(1)
13		131-37906	SPRING BUSHING	ハネツマユ	(1)
14		131-38102	THREAD TENSION SPRING FELT	イトチュウツハネサフェルト	(1)
15		131-38201	THREAD TENSION DISK	イトチュウツサラ	(2)
16		131-38003	THREAD TENSION RUBBER WASHER	イトチュウツゴムサシ	(1)
17	04	SS-8110410-TP	SCREW 11/64-40 L= 3.5	トメネジ 11/64-40 L=3.5	2
18	02	132-25107	TESION DISK THREAD GUIDE	チュウツサライトアンナイ	3
19	03	132-25107	TESION DISK THREAD GUIDE	チュウツサライトアンナイ	4
20	04	131-39555	THREAD TENSION POST COMPL.	ツタイトチュウツハネウケツゴウウ	1
21		131-40009	THREAD TENSION POST	ツタイトチュウツハネウ	(1)
22		131-39605	TESION DISK THREAD GUIDE	チュウツサライトアンナイ	(1)
23		131-39902	THREAD TENSION SPRING FELT	イトチュウツハネサフェルト	(1)
24		131-39803	THREAD TENSION NUT	ツタイトチュウツナット	(1)
25		131-39704	THREAD TENSION SPRING	ツタイトチュウツハネ	(1)
26		229-21407	ROTATION STOPPER	イトチュウツサライカレントメ	(1)
27		131-38201	THREAD TENSION DISK	イトチュウツサラ	(2)
28	04	PS-0200052-KH	SPRING PIN 2.3X5	スプリングピン 2.3X 5	1
29	02	SS-7110710-SL	SCREW 11/64-40 L=7.0	マルヒラネジ 11/64-40 L=7	1
30		SS-4110615-SP	SCREW 11/64-40 L=6	ナハネジ 11/64-40 L=6	2
31	04	131-28202	THREAD CAM THREAD GUIDE BASE	ツタイトカムイトアンナイダイ	1
32	04	131-28301	THREAD CAM THREAD GUIDE A	ツタイトカムイトアンナイ A	1
33	04	131-28400	THREAD CAM THREAD GUIDE B	ツタイトカムイトアンナイ B	1
34	04	131-28509	LOWER THREAD CAM HOOK	ツタイトカムツマ	1
35	04	131-28608	LOWER THREAD GUIDE	ツタイトアンナイ	1
36	04	131-28707	THREAD GUIDE BASE SPRING	イトアンナイダイトメハネ	1
37	04	131-28905	LOOPER THREAD CAM COMPL.	ツタイトウカン	1
38	04	131-29457	LOWER THREAD CAM COMPL.	ツタイトカムケツゴウウ	1
39	04	B2202-816-000	SHAFT	ツタイトカムシャフト	1
40	04	131-29101	LOWER THREAD CONDUIT GUIDE	ツタイトウカンアンナイ	1
41	04	131-29200	MOUNTING BRACKET	ツタルハネイトウカンダイ	1
42	04	SD-0600341-TP	HINGE SCREW D=6.0 H=3.4	タネネジ	1
43	04	WZ-0640312-K0	WAVED WASHER	ナミカタサカネ 6.4X11X0.3	1
44	04	SM-4050855-SP	SCREW M5 L=8	ナハネジ M5 L=8	1
45	04	SS-4090415-SP	SCREW 9/64-40 L=4	ナハネジ 9/64-40 L=4	1
46	04	SS-4090415-SP	SCREW 9/64-40 L=4	ナハネジ 9/64-40 L=4	1
47	04	SS-4090415-SP	SCREW 9/64-40 L=4	ナハネジ 9/64-40 L=4	1
48	04	SS-4090415-SP	SCREW 9/64-40 L=4	ナハネジ 9/64-40 L=4	1
49	04	SS-4110515-SP	SCREW 11/64-40 L=5	ナハネジ 11/64-40 L=5	1
50	04	SS-5150510-SP	SCREW 15/64-28 L=5	トラスネジ 15/64-28 L=5	1

NOTE (注記) 01....FOR MO-6704S(1 PC. IS USED.) MO-6704S用 (1個使い)
FOR MO-6714S,MO-6916S MO-6714S,MO-6716S用 (2個使い)
(2 PC. ARE USED.)
02....FOR MO-6704S MO-6704S用
03....FOR MO-6714S,MO-6716S MO-6714S,MO-6716S用
04....FOR MO-6716S MO-6716S用

12. LOWER KNIFE COMPONENTS

下メス関係

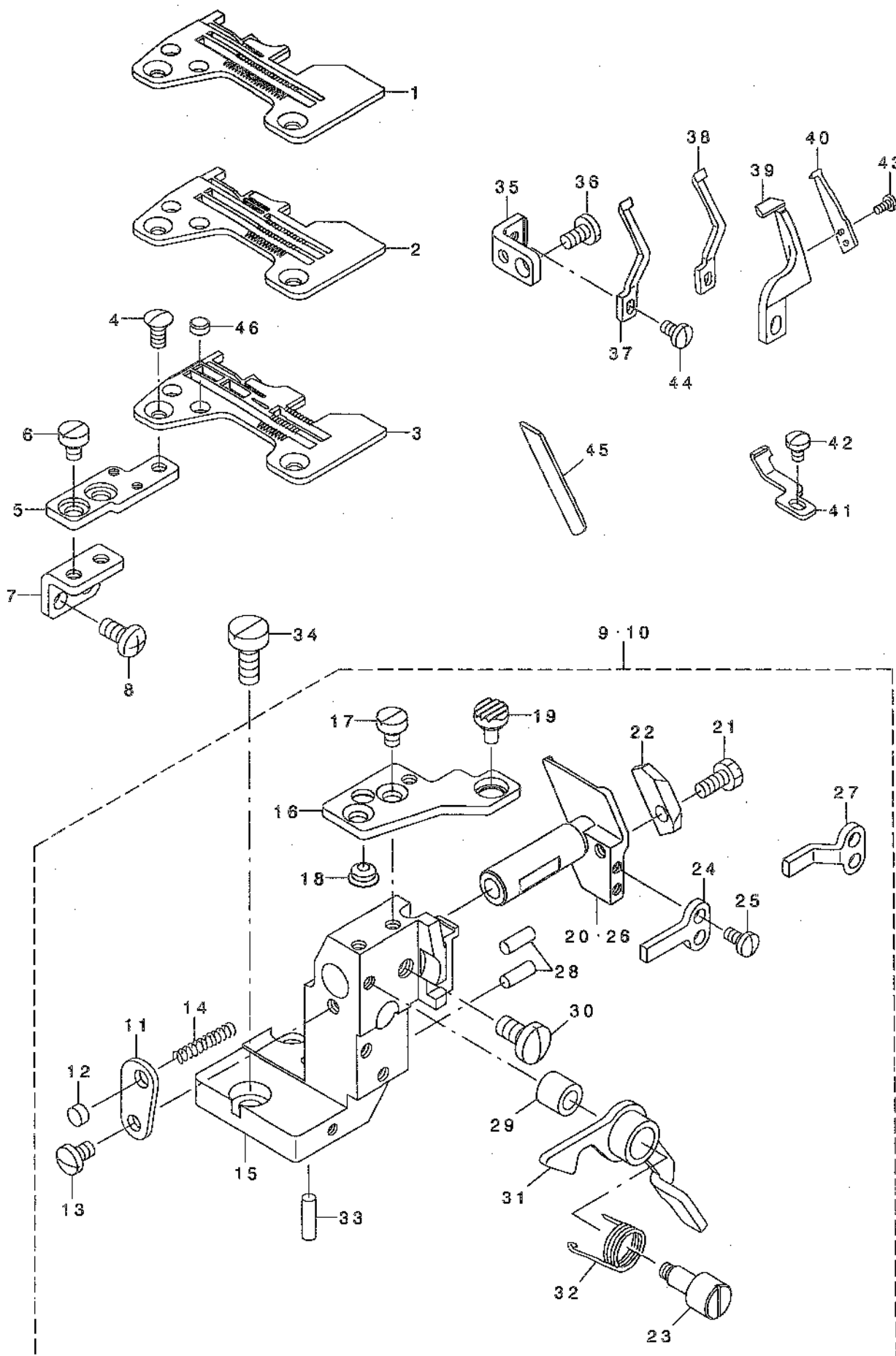

REF. NO	NOTE	PART NO.	DESCRIPTION	ルリイタ	Qty
1	01	R4200-J6E-D00	THROAT PLATE	ハリイタ	1
2	02	R4305-J6E-E00	THROAT PLATE	ハリイタ	1
3	03	R4508-J6E-D00	THROAT PLATE	ハリイタ	1
4		SS-2110910-SL	SCREW 11/64-40 L=9	マルサラネジ 11/64-40 L=8.5	2
5		131-51204	THROAT PLATE BASE B	ハリイタイ(B)	1
6		SS-6110610-TP	SCREW 11/64-40 L=6	ヒラネジ 11/64-40 L=6	2
7		122-88908	THROAT PLATE BASE B SUPPORT	ハリイタイ(B)ササエ	1
8		SM-4051055-SP	SCREW	ナハネジ	2
9	04	123-47167	LOWER KNIFE BRACKET ASM.	シタメストリツケタイクミ	1
10	03	123-47266	LOWER KNIFE BRACKET ASM.	シタメストリツケタイクミ	1
11		121-33211	SPRING STOPPER	シタメスハ ネットメイタ	(1)
12		118-06304	PLUG	ハリイタフタ	(1)
13		SS-7110720-SP	SCREW 11/64-40 L=7	マルヒラネジ 11/64-40 L=7	(1)
14		118-46607	SPRING	シタメス スライト シクハネ	(1)
15		121-32619	LOWER KNIFE BRACKET	シタメストリツケタイ	(1)
16		121-02208	THROAT PLATE BASE A	ハリイタイ A	(1)
17		SS-6110610-TP	SCREW 11/64-40 L=6	ヒラネジ 11/64-40 L=6	(2)
18		121-03701	RUBBER PLUG B	ヌノダイホウウツシゴ AB	(1)
19		132-35304	RUBBER PLUG A	ヌノダイホウウツシゴ AA	(1)
20	04	121-32700	LOWER KNIFE SLIDE STUD	シタメス スライト シク	(1)
21		SS-9111010-SP	SCREW 11/64-40 L=9.5	ロツカクネジ 11/64-40 L=9.5	(1)
22		121-33104	LOWER KNIFE PRESSER PLATE	シタメス ササエ	(1)
23		121-02810	LEVER SHAFT	ヌノダイカイハイレハ シク	(1)
24	04	121-32908	ROTATING STOPPER	シタメススライト シク マワリトメ	(1)
25		SS-7090710-SP	SCREW 9/64-40 L= 6.8	マルヒラネジ 9/64-40 L=6.8	(2)
26	03	121-32809	LOWER KNIFE SLIDE STUD	シタメス スライト シク	(1)
27	03	121-33005	ROTATING STOPPER	シタメス スライト シク マワリトメ	(1)
28		118-46805	HOLDER PIN	ササエピン	(2)
29		121-03107	RUBBER PLUG	カイハイレハ -ホウウツシゴ アツシユ	(1)
30		SS-7151120-SP	SCREW 15/64-28 L=11	マルヒラネジ 15/64-28 L=11	(1)
31		121-02950	LEVER ASM.	ヌノダイカイハイレハ -クミ	(1)
32		118-02006	LEVER SPRING	ヌノダイカイハイレハ -ハネ	(1)
33		118-46805	HOLDER PIN	ササエピン	(1)
34		SS-6151440-SP	SCREW 15/64-28 L=14	ヒラネジ 15/64-28 L=14	2
35		131-51105	NEEDLE HOLDER SUPPORT	ハリウケササエ	1
36		SS-7110840-SP	SCREW 11/64-40 L=7.8	マルヒラネジ 11/64-40 L=7.8	1
37	01	118-90100	NEEDLE GUARD	ハリウケ	1
38	02	118-90308	NEEDLE GUARD	ハリウケ	1
39	03	120-15301	NEEDLE HOLDER	ハリウケ	1
40	03	120-15400	NEEDLE HOLDER	ハリウケ	1
41	03	121-77903	NEEDLE HOLDER	ハリウケ	1
42	03	SS-7090510-SP	SCREW 9/64-40 L= 4.6	マルヒラネジ 9/64-40 L=4.6	1
43	03	SS-7060510-SP	SCREW 3/32-56 L=4.8	マルヒラネジ 3/32-56 L=4.8	2
44		SS-7090610-SP	SCREW 9/64-40 L=6	マルヒラネジ 9/64-40 L=6	1
45		131-50701	LOWER KNIFE	シタメス	1
46		131-02702	THROAT PLATE COVER	ハリイタフタ	2
		NOTE (注記)	01....FOR MO-6704S	MO-6704S用	
			02....FOR MO-6714S	MO-6714S用	
			03....FOR MO-6716S	MO-6716S用	
			04....FOR MO-6704S,MO-6714S	MO-6704S,MO-6714S用	

13. UPPER KNIFE COMPONENTS

上メス関係

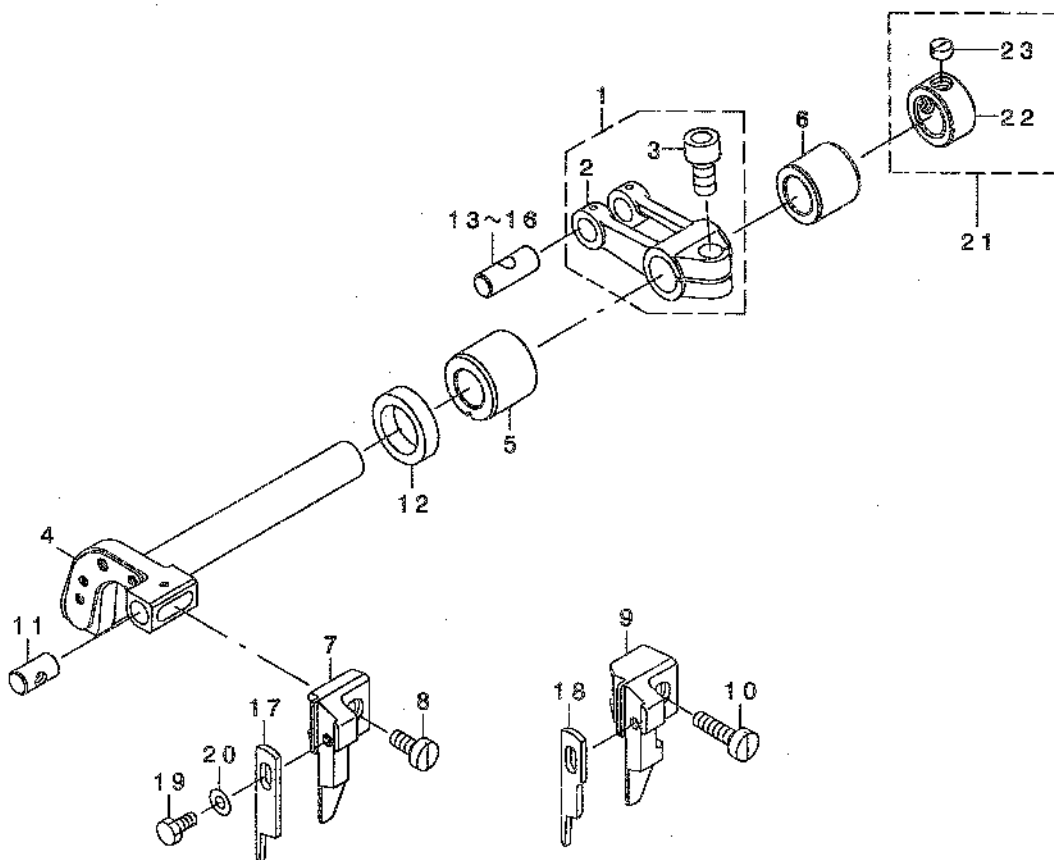

REF. NO	NOTE	PART NO.	DESCRIPTION	ヒソメイ	Qty
1		131-47558	FEED FORKED ARM ASM.	ウラメスアタマタカデ' クミ	1
2		131-47509	FEED FORKED ARM	ウラメスアタマタカデ'	(1)
3		SM-6061402-TP	SCREW M6 L=14	ロツカク' ア' ナネ' M6 L=14	(1)
4		131-51303	KNIFE DRIVING ARM SHAFT	メスウチ' シ' ク	1
5		131-50909	BUSHING, FRONT	ウラメス' クマエメタル	1
6		131-51006	BUSHING, REAR	ウラメス' クウシロメタル	1
7	01	131-47400	PLAIN KNIFE SUPPORT A	ヒラメスササエ(A)	1
8	01	SS-6111040-SP	SCREW 11/64-40 L=9.5	ヒラネシ' 11/64-40 L=9.5	1
9	02	131-47301	PLAIN KNIFE SUPPORT	ヒラメスササエ	1
10	02	SS-6111610-SP	SCREW 11/64-40 L=16	ヒラネシ' 11/64-40 L=16	1
11		131-50800	UPPER KNIFE GUIDE SHAFT	ウラメスガ' イト' シ' ク	1
12		115-66809	OIL SEAL	ウラメス' ク オイルシ-ル	1
13	03	131-22007	CRANK PIN A	オクリアタマタクラソクビ' シ' A	1
14	03	131-22106	CRANK PIN B	オクリアタマタクラソクビ' シ' B	1
15	03	131-22205	CRANK PIN C	オクリアタマタクラソクビ' シ' C	1
16	03	131-22304	CRANK PIN D	オクリアタマタクラソクビ' シ' D	1
17	01	131-50503	PLAIN KNIFE	ヒラメス	1
18	02	131-50602	PLAIN KNIFE	ヒラメス	1
19		SS-9090823-TP	BOLT 9/64-40 L=8	ロツカク' ホ' ルト	1
20		WP-0370316-SD	WASHER 3.7X8X0.3	ヒラサ' ガ' ネ 3.7X8X0.3	1
21		CS-111101H-SH	THRUST COLLAR ASM.	シ' ヨウケ' シ' クスラストカラ-(クミ)	1
22		CS-1111019-SH	THRUST COLLAR D=11.11 W=10	スラストウケ D=11.11 W=10	(1)
23		SS-8660330-SP	SCREW 1/4-40 L=3.0	トメネシ' 1/4-40 L=3	(1)

NOTE (注記)

01...FOR MO-6704S, MO-6714S

02...FOR MO-6716S

03...SELECTIVE PARTS

MO-6704S, MO-6714S用

MO-6716S用

選択部品

14. NEEDLE COOLING MECHANISM COMPONENTS (FOR SH)

針冷却装置関係 (SH用)

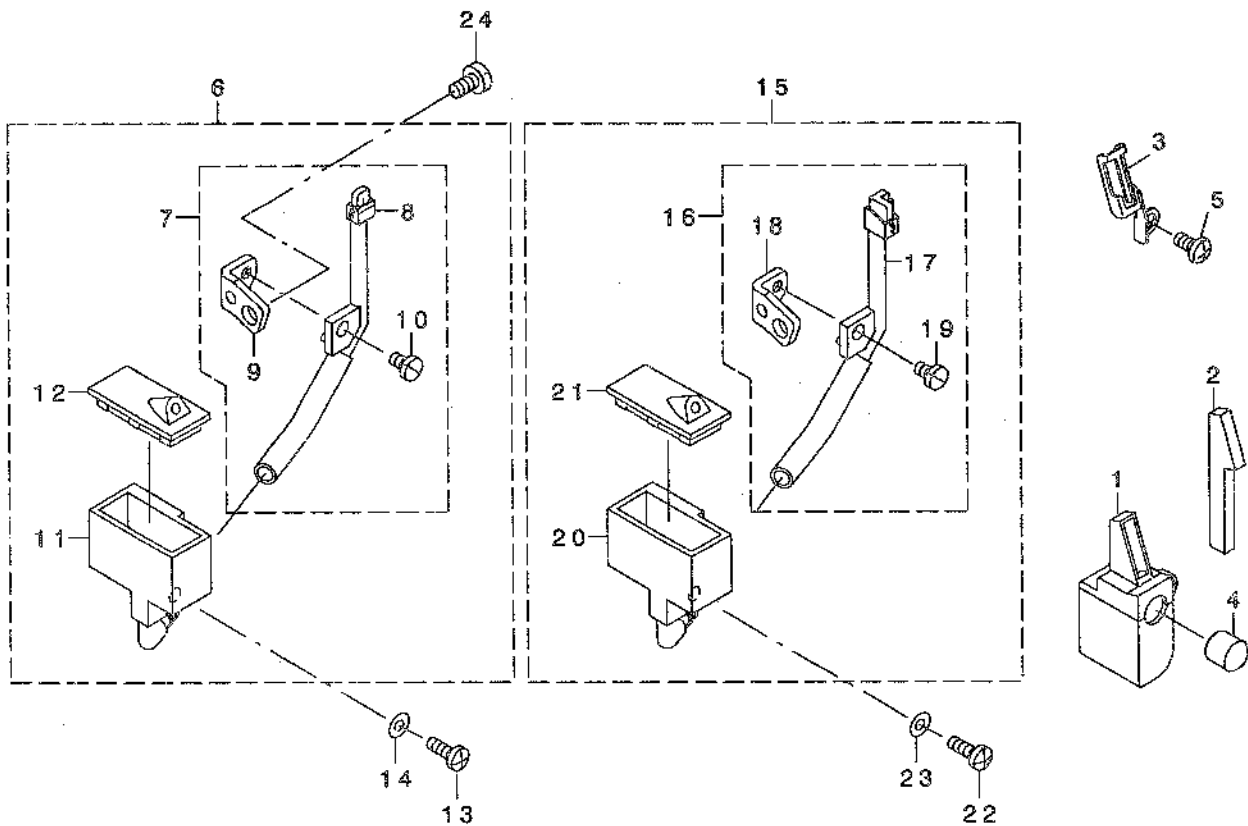

REF. NO	NOTE	PART NO.	DESCRIPTION	品名	Qty
1		131-63456	SILICON TANK ASM.	シリコンタンク	1
2		131-63803	NEEDLE THREAD FELT	針糸フェルト	1
3		131-63902	NEEDLE THREAD FELT PRESSER	針糸フェルト押し	1
4		TA-0950306-R0	RUBBER PLUG	ゴム栓	1
5		SM-4040855-SP	SCREW	ナット	1
6	01	131-62557	NEEDLE COOLER UNIT ASM. (OVER)	ハリレイヤクサシ(オーバー)クミ	1
7		131-62565	NEEDLE COOLER UNIT COMPL.	ハリレイヤクサシ(オーバー)クミ	(1)
8		131-62573	NEEDLE COOLER UNIT ASM. (OVER)	ハリレイヤクサシ(オーバー)クミ	(1)
9		131-62805	NEEDLE COOLER SUPPORT	ハリレイヤクサシ	(1)
10		SS-7090610-SP	SCREW 9/64-40 L=6	マルヒラネジ 9/64-40 L=6	(1)
11		131-62904	TANK	シリコンタンク	(1)
12		131-63001	TANK COVER	シリコンタンクカバー	(1)
13		SS-4091015-SP	SCREW 9/64-40 L=10	ナット 9/64-40 L=10	1
14		WP-0371026-SD	WASHER 3.7X7X1	ワッシャー 3.7X7X1	1
15	02	131-63159	NEEDLE COOLER UNIT ASM. (INTER)	ハリレイヤクサシ(インター)クミ	1
16		131-63167	NEEDLE COOLER COMPL. (INTER)	ハリレイヤクサシ(インター)クミ	(1)
17		131-63175	NEEDLE COOLER ASM. (INTER)	ハリレイヤクサシ(インター)クミ	(1)
18		131-62805	NEEDLE COOLER SUPPORT	ハリレイヤクサシ	(1)
19		SS-7090610-SP	SCREW 9/64-40 L=6	マルヒラネジ 9/64-40 L=6	(1)
20		131-62904	TANK	シリコンタンク	(1)
21		131-63001	TANK COVER	シリコンタンクカバー	(1)
22		SS-4091015-SP	SCREW 9/64-40 L=10	ナット 9/64-40 L=10	1
23		WP-0371026-SD	WASHER 3.7X7X1	ワッシャー 3.7X7X1	1
24		SS-7110840-SP	SCREW 11/64-40 L=7.8	マルヒラネジ 11/64-40 L=7.8	1
	NOTE (注記)	01...FOR MO-6704S, MO-6714S		MO-6704S, MO-6714S用	
		02...FOR MO-6716S		MO-6716S用	

15. LUBRICATION MECHANISM COMPONENTS

給油装置関係

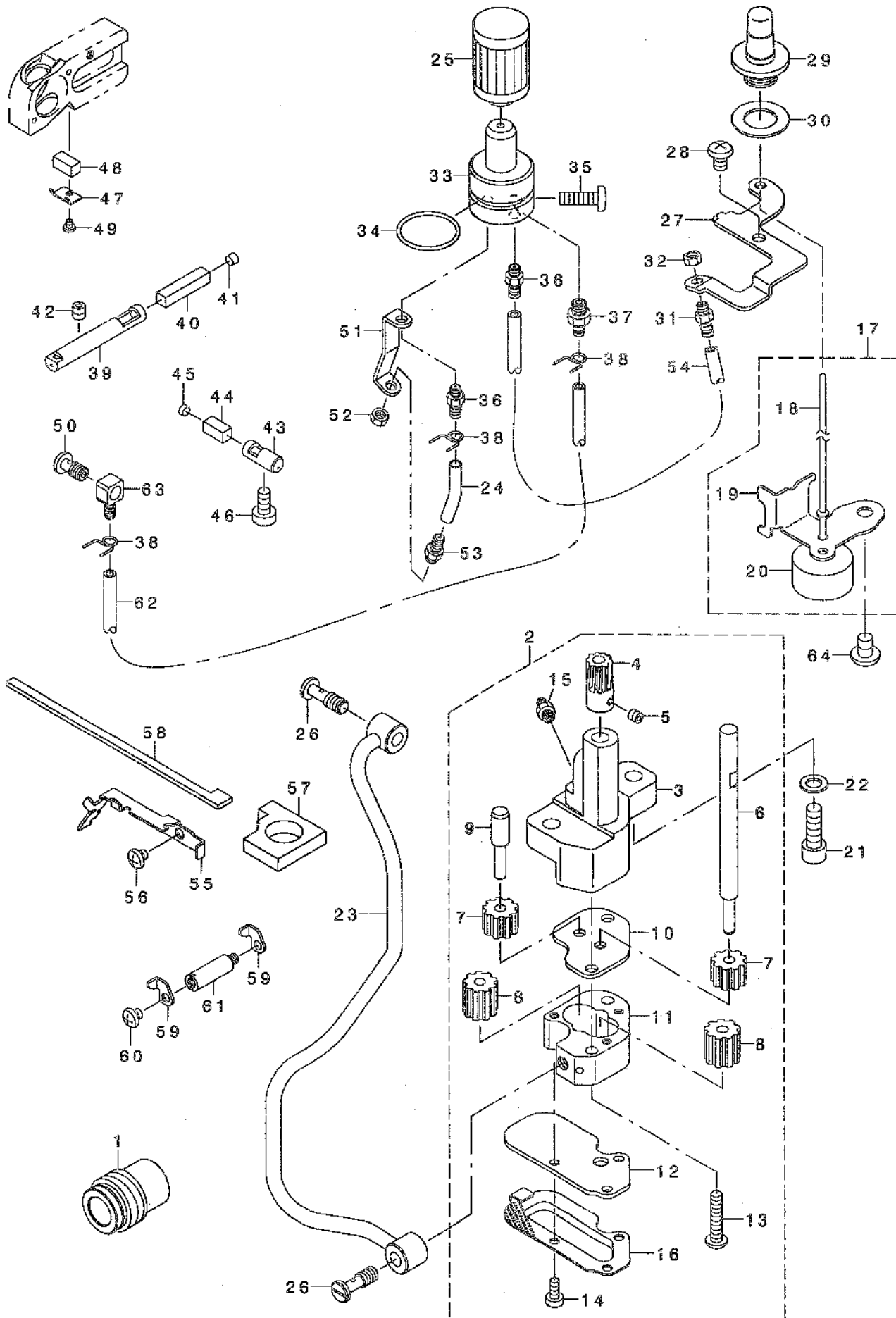

REF. NO	NOTE	PART NO.	DESCRIPTION	品名	Qty
1		132-30305	WORM	ウオ-A	1
2		400-18044	OIL PUMP ASM	キユウポン プア タイツツコウ	1
3		123-15909	OIL PUMP	キユウポン プア タイ	(1)
4	*	133-43009	WORM WHEEL	ウオ-ムホイ-ル	(1)
5	*	SM-8050412-TP	SCREW M5 L=4	トメネツ M5 L=4	(2)
6		119-18109	GEAR PUMP SHAFT LARGE	ギヤポン プア ツク タイ	(1)
7		B3534-352-00G	PINION GEAR	ピニオン	(2)
8		118-40303	OIL PUMP PINION	ポン プア ヨウ ピニオン	(2)
9		123-17004	GEAR PUMP SHAFT	ギヤポン プア ツク (ツヨウ)	(1)
10		123-16006	PINION SPACER	ピニオンスペーサー	(1)
11		123-16105	CASING	ケーシング	(1)
12		400-16762	PUMP COVER	ポン プア カバ-	(1)
13		SS-4112215-SP	SCREW 11/64-40 L=22	ナハネツ 11/64-40 L=22	(2)
14		SS-6090810-SP	SCREW 9/64-40 L=7.5	ヒラネツ 9/64-40 L=7.5	(3)
15		SQ-1110401-MZ	CONNECTING SCREW	チューブ レンケツネツ	(1)
16		400-16763	PUMP NET	ポン プア アミ	(1)
17		132-29356	FLOAT ASM.	ウキコクミ	1
18		121-29904	OIL GAUGE BAR	ユリヨウツツネツ	(1)
19		132-29307	FLOAT SUPPORT	ウキコササエ	(1)
20		121-29805	FLOAT	ウキコ	(1)
21		SM-6061802-TP	SCREW M6 L=18	ロツカクナツネツ	2
22		WP-0651056-SD	WASHER 6.5X11X1	ヒラサネ ガネ 6.5X11X1	2
23		132-28655	LUBRICATION MECHANISM PIPE ASM	キユウポン イア クミ	1
24		BP-3000001-OR	VINYL PIPE	ビニールパイプ	0.03
25		131-42500	CARTRIDGE FILTER	カートリッジ フィルタ	1
26		SQ-1150454-SD	CONNECTING SCREW	パイプ レンケツネツ	2
27		131-43805	EXHAUST PORT SUPPORT	トシュツク ササエ	1
28		SM-4050855-SP	SCREW	ナハネツ M5 L=8	1
29		131-43300	OIL GAUGE	オイルゲージ	1
30		131-44001	OIL GAUGE GASKET	オイルゲージ パッキン	1
31		SQ-1110451-MZ	CONNECTING SCREW	パイプ レンケツネツ	1
32		NS-6110310-SP	NUT 11/64-40	ロツカクナツ 11/64-40	1
33		131-42955	FILTER GUIDE ASM.	フィルターガイド (クミ)	1
34		131-70808	RUBBER RING	Oリング	1
35		SM-4051601-SC	SCREW M5X0.8 L=16	ナハネツ M5X0.8 L=16	1
36		SQ-1110451-MZ	CONNECTING SCREW	パイプ レンケツネツ	2
37		SQ-1150451-MZ	CONNECTING SCREW	チューブ レンケツネツ	1
38		131-42609	OIL TUBE HOLDER	パイプホルダ	3
39		131-44100	OILING PIN	ハリキユウピン	1
40		131-44209	OIL FELT	ハリキユウピンのフェルト	1
41		TA-0400301-MO	PLUG D=4X4.5 L=3	トメピン D=4X4.5 L=3	1
42		SM-8050502-TP	SCREW M5 L=5	トメネツ	1
43		131-43417	UPPER LOOPER OILING PIN	ウワル-ハネ キユウピン	1
44		131-43508	OIL FELT	ウワル-ハネ キユウピンのフェルト	1
45		132-30107	UPPER LOOPER OILING PIN PLUG	ウワル-ハネ キユウピンのトメピン	1
46		SS-6121020-SP	SCREW 3/16-28 L=9.5	ヒラネツ 3/16-28 L=9.5	1
47		131-43607	OIL FELT PRESSER	ウワル-ハネ キユウピンのオサエ	1
48		131-43706	OIL FELT	ウワル-ハネ キユウピンのフェルト	1
49		SS-7060310-SP	SCREW 3/32-56 L=3	マダヒラネツ 3/32-56 L=3	1
50		SQ-1150441-SD	CONNECTING SCREW	パイプ レンケツネツ	1
51		132-29208	WORM EXHAUST PORT GUIDE	ウオ-ムトシュツクガイド	1
52		NS-6110310-SP	NUT 11/64-40	ロツカクナツ 11/64-40	1
53		SQ-1110451-MZ	CONNECTING SCREW	パイプ レンケツネツ	1
54		236-30007	TUBE	チューブ	0.17
55		132-28804	OIL FELT GUIDE	ハリクトウピンのキユウピンのフェルトガイド	1
56		310-18005	SCREW	ナハネツ	2
57		132-29109	OIL FELT B	ハリクトウピンのキユウピンのフェルトB	1
58		132-29406	OIL FELT A	ハリクトウピンのキユウピンのフェルトA	1
59		132-28903	OIL FELT PRESSER	ハリクトウピンのキユウピンのオサエ	2
60		310-18005	SCREW	ナハネツ	1
61		132-29000	FELT PRESSER SPACER	ハリキユウピンのオサエスペーサー	1
62		BP-3000001-OR	VINYL PIPE	ビニールパイプ	0.29
63		SQ-0000451-MZ	CONNECTING SCREW	パイプ レンケツネツ	1
64		SM-4060801-SE	SCREW	ナハネツ	1

16. SEMI-SUNKEN TYPE TABLE COMPONENTS

卓上式テーブル関係

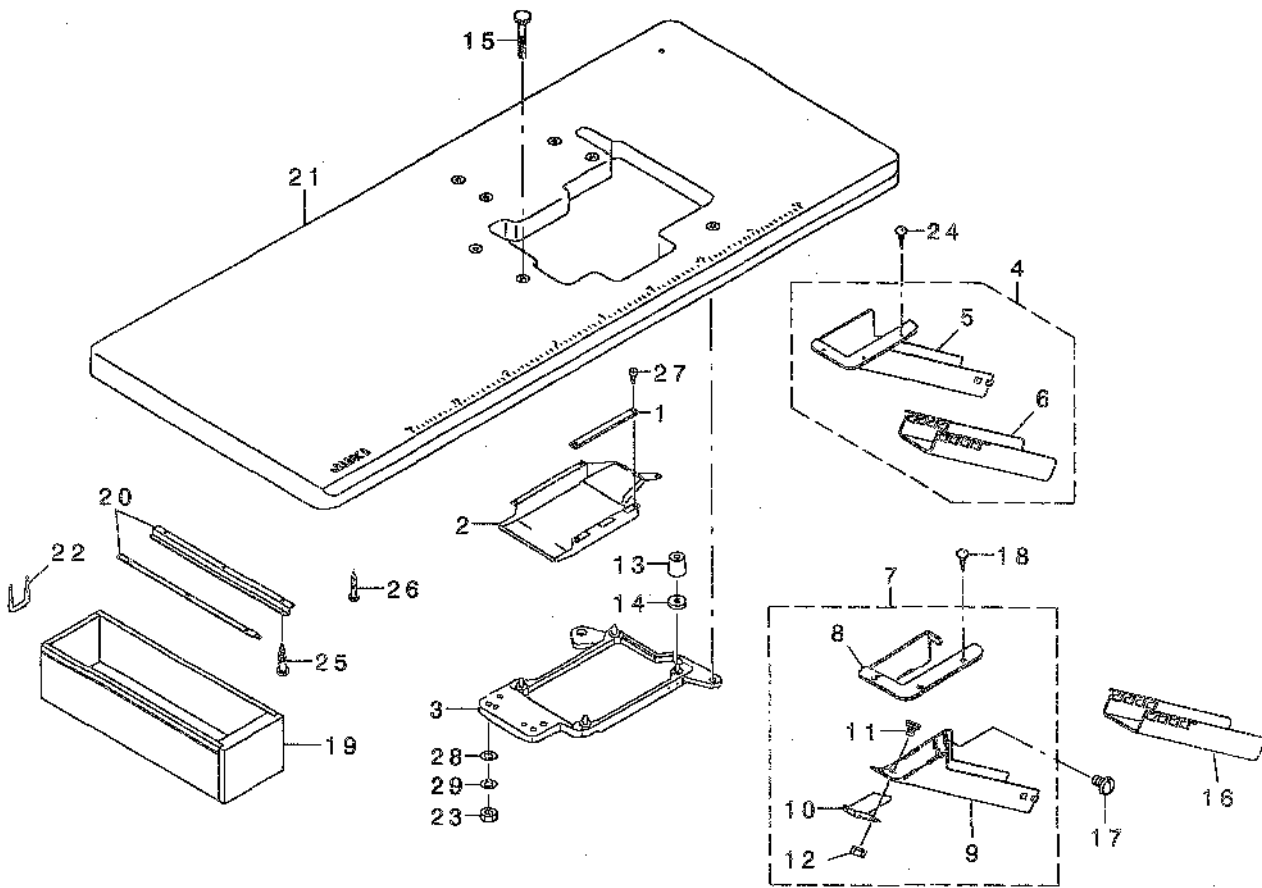

REF. NO	NOTE	PART NO.	DESCRIPTION	エ ヲ キ イ	Qty
1		131-61005	CASE SPONGE	ケース綿	1
2		131-60908	COOLING FAN CASE	ソーアケース	1
3		131-61153	FRAME SUPPORT PLATE ASM.	フレームケイタキ	1
4	01	123-41954	CLOTH WASTE CHUTE ASM.	スリウス ヌート(タツ) ヨウ	1
5		123-41905	CLOTH WASTE CHUTE(SEMI-SUNKEN)	スリウス ヌート(タツ) ヨウ	(1)
6		123-41806	CLOTH WASTE CHUTE	スリウス ヌート	(1)
7	02	131-55759	CLOTH WASTE CHUTE ASM.	スリウス ヌート(クミ)	1
8		131-55601	CLOTH WASTE CHUTE INLET	スリウス ヌートグチ	(1)
9		131-55700	CLOTH WASTE CHUTE, UPPER	スリウス ヌートウエ	(1)
10		131-55502	CHUTE SUPPORT	シュートサチエ	(1)
11		SS-5090610-SP	SCREW 9/64-40 L=6	トラスネツ 9/64-40 L=6	(3)
12		NS-6090310-SP	NUT 9/64-40	ワカクナツト 9/64-40	(3)
13		131-55403	DUST-PROOF RUBBER	ダウツゴ A	4
14		131-56500	DUST-PROOF RUBBER SPACER	ダウツゴ Δスバ-チ	4
15		131-55007	HOLDING PLATE BOLT	ウケイタキ ねト	4
16	02	123-41806	CLOTH WASTE CHUTE	スリウス ヌート	1
17	02	SS-5110710-SP	SCREW 11/64-40 L=7	トラスネツ 11/64-40 L=7	2
18	02	SK-2351600-SC	WOOD SCREW D=3.5 L=16	マツクネツ	3
19		111-55108	DRAWER	ヒキダシ	1
20		111-55207	DRAWER SUPPORT	ヒキダシ サチエ	2
21		119-59400	TABLE (SEMI-SUNKEN)	テーブル (タツ) ヨウ	1
22		D8204-555-D00	DRAWER STOPPER	ヒキダシ ストツパ-	1
23		NS-6240630-SE	NUT 3/8-18	ワカクナツト	4
24	01	SK-2351600-SC	WOOD SCREW D=3.5 L=16	マツクネツ	3
25		SK-3311500-SC	WOOD SCREW D=3.1 L=15	マツクネツ D=3.1 L=15	6
26		SK-3513200-SC	WOOD SCREW D=5.1 L=32	マツクネツ D=5.1 L=32	4
27		SS-6090630-TP	SCREW 9/64-40 L=6	ヒラネツ 9/64-40 L=6	5
28		WP-1002036-SE	WASHER 10X21X2	ヒラダシ カネ	4
29		WS-1002560-KR	SPRING WASHER 10X18X2.5	ハネダシ カネ 10X18X2.5	4

NOTE (注記)

01...EXCEPT JE
02...FOR JE

JEは除く
JE用

17. FULLY-SUNKEN TYPE TABLE COMPONENTS

全沈式テーブル関係

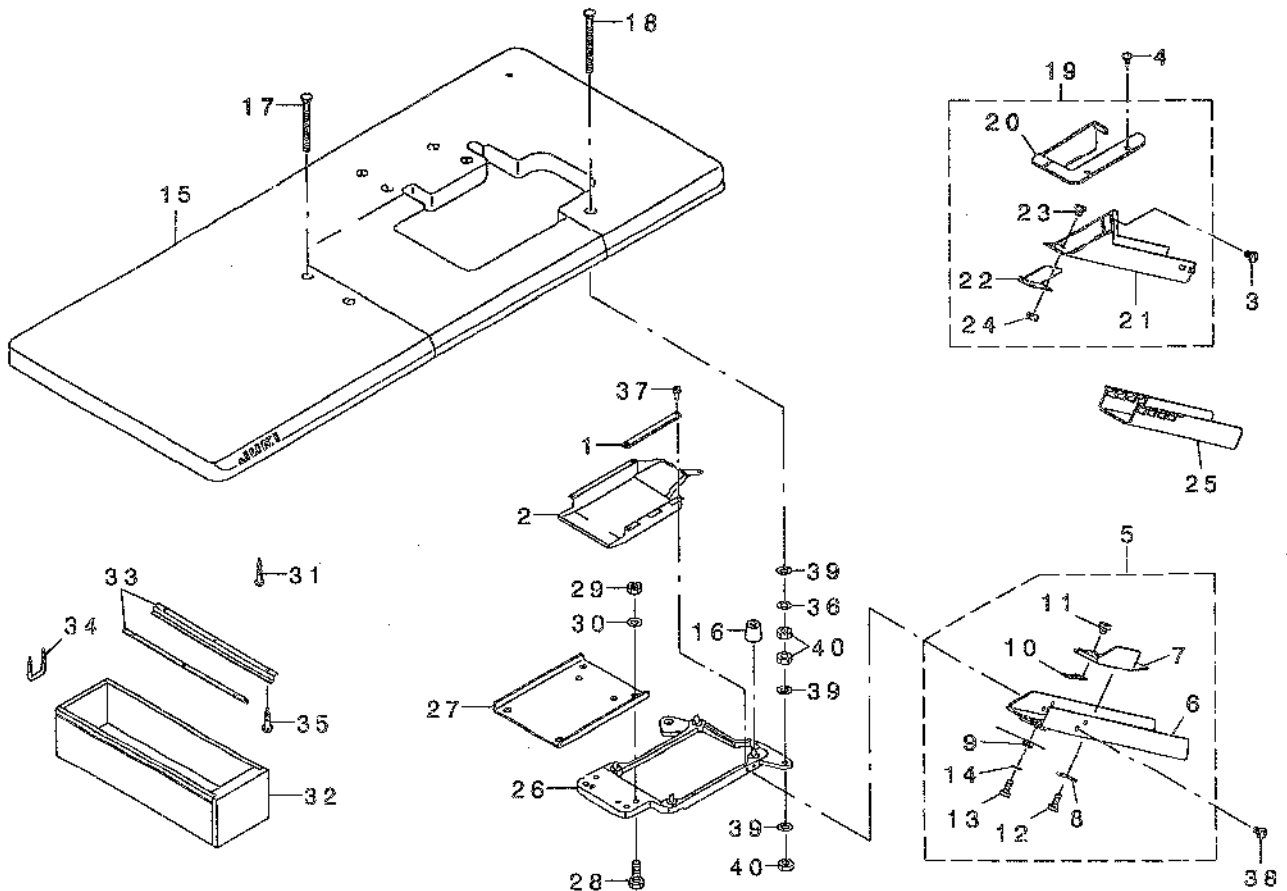

REF. NO	NOTE	PART NO.	DESCRIPTION	品名	Qty
1		131-61005	CASE SPONGE	ケーススポンジ	1
2		131-60808	COOLING FAN CASE	ソフケース	1
3	02	SS-5110710-SP	SCREW 11/64-40 L=7	トラスネジ 11/64-40 L=7	2
4	02	SK-2351600-SC	WOOD SCREW D=3.5 L=16	丸目ネジ D=3.5 L=16	3
5	01	131-55858	CLOTH WASTE CHUTE ASM.	スリクズシュート(ベントン)組み	1
6		131-56203	CLOTH WASTE CHUTE	スリクズシュート(ベントン)	(1)
7		131-56302	CLOTH WASTE CHUTE INLET	スリクズシュートゲテ	(1)
8		131-55908	CHUTE INLET LEVER	シュートゲレバ	(1)
9		131-56005	CHUTE INLET SPRING	シュートゲチカネ	(1)
10		131-56104	CHUTE INLET RUBBER	シュートゲチゴム	(1)
11		SS-6090420-SF	SCREW 9/64-40 L= 4.0	ビスネジ 9/64-40 L=4	(2)
12		ST-6030821-0A	SCREW D=3-24 L=8	スチールネジ D=3-24 L=8	(2)
13		ST-6030821-0A	SCREW D=3-24 L=8	スチールネジ D=3-24 L=8	(1)
14		WP-0370315-SD	WASHER 3.7X8X0.3	ビワシガネ 3.7X8X0.3	(1)
15		119-59858	TABLE ASM.	テーブル(ベントン)組み	1
16		131-55403	DUST-PROOF RUBBER	ホコリゴム	4
17		131-55106	HOLDING PLATE BOLT C	ホールドプレートボルト(C)	2
18		131-55205	HOLDING PLATE BOLT D	ホールドプレートボルト(D)	2
19	02	131-56759	CLOTH WASTE CHUTE ASM.	スリクズシュート(組み)	1
20		131-56601	CLOTH WASTE CHUTE INLET	スリクズシュートゲテ	(1)
21		131-55700	CLOTH WASTE CHUTE, UPPER	スリクズシュート上	(1)
22		131-55502	CHUTE SUPPORT	シュートサポ	(1)
23		SS 5090610 SP	SCREW 9/64-40 L=6	トラスネジ 9/64-40 L=6	(3)
24		NS-6090310 SF	NUT 9/64-40	ワッシャーナット 9/64-40	(3)
25	02	123-41806	CLOTH WASTE CHUTE	スリクズシュート	1
26		131-61153	FRAME SUPPORT PLATE ASM.	フレームサポートプレート組み	1
27		131-55304	FRAME HOLDING PLATE COUPLING	フレームサポートプレート	1
28		SM-9082513-CF	SCREW M8 L=25	ワッシャーネジ M8 L=25	4
29		NM-6080600-SH	NUT M8	ワッシャーナット M8	4
30		WP-0850002-SC	WASHER 8.5X18X1.6	ビワシガネ 8.5X18X1.6	4
31		SK-3513200-SC	WOOD SCREW D=5.1 L=32	丸目ネジ D=5.1 L=32	4
32		111-55108	DRAWER	引き出し	1
33		111-55207	DRAWER SUPPORT	引き出しサポ	2
34		D8204-555-D00	DRAWER STOPPER	引き出しストッパー	1
35		SK-3311500 SC	WOOD SCREW D=3.1 L=15	丸目ネジ D=3.1 L=15	6
36		WS-1002560-KR	SPRING WASHER 10X18X2.5	バネシガネ 10X18X2.5	4
37		SS-6090630-TP	SCREW 9/64-40 L=6	ビスネジ 9/64-40 L=6	5
38	01	SS-5110710-SP	SCREW 11/64-40 L=7	トラスネジ 11/64-40 L=7	2
39		WP-1002036-SE	WASHER 10X21X2	ビワシガネ	12
40		NS-6240630-SE	NUT 3/8-18	ワッシャーナット	12

NOTE (注記) 01....EXCEPT JE
02....FOR JE

JEは除く
JE用

18. STAND COMPONENTS (Z · T)

脚關係 (Z · T)

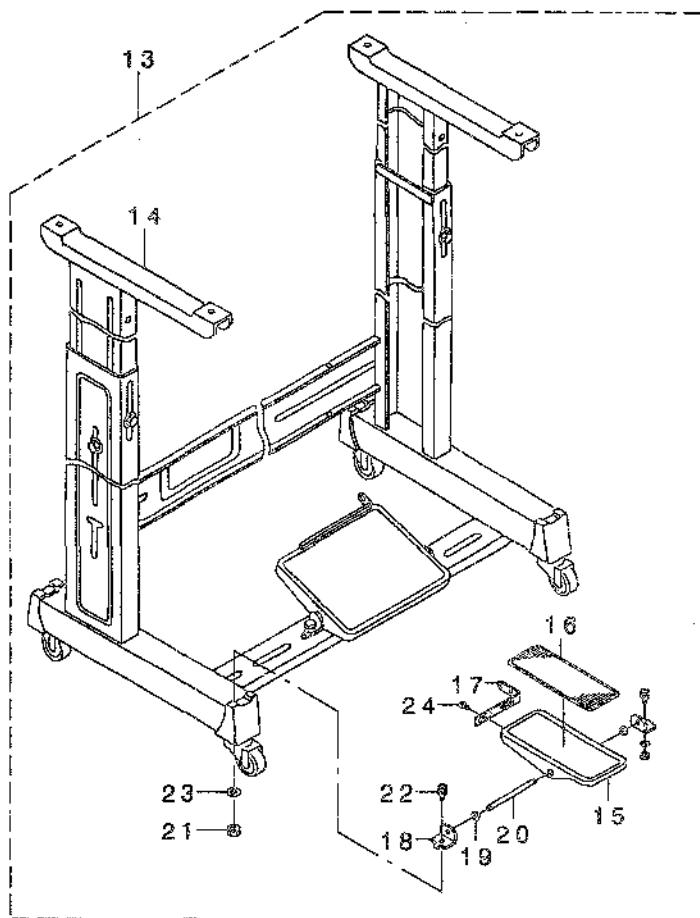
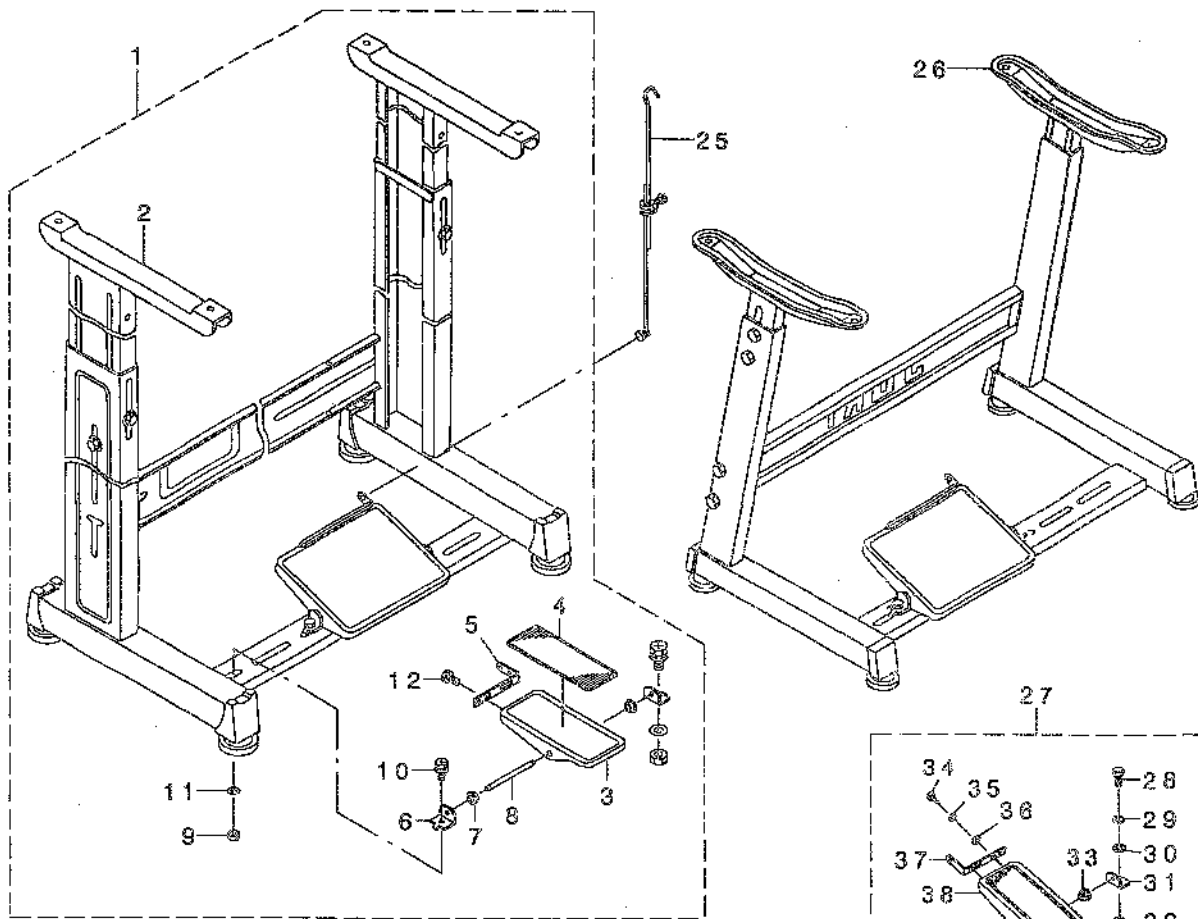

REF. NO	NOTE	PART NO.	DESCRIPTION	ト ヲ メ イ	Qty
1		119-60655	T STAND JUNCTION	Tキヤクケツゴウ	1
2		111-57567	T LEG JUNCTION	Tキヤクケツゴウ	(1)
3		GPF-06060000	PEDAL	ハダール	(1)
4		GPF-06070000	PEDAL MAT	ハダールマット	(1)
5		GPF-06080000	PEDAL ADJUSTING PLATE	フミイタ チョウセツハン	(1)
6		111-59001	PEDAL SHAFT BRACKET	フミイタ シクウケ	(2)
7		D8113-555-B00	PEDAL BUSHING	フミイタ フツユ	(2)
8		B8153-771-000	PEDAL CONNECTING ROD	ハダールツク	(1)
9		NM-6080001-SE	NUT M8	ロツカクナツト M8 1ツユ	(2)
10		SL-9082091-SE	WASHER HEXAGONAL BOLT	サカネツキロツカクホルト	(2)
11		WP-0871602-SE	WASHER 8.7X18X1.6	ヒラサカネ 8.7X18X1.6	(2)
12		SL-9061291-SE	WASHER HEXAGONAL BOLT M6 L=12	サカネツキロツカクホルト	(2)
13		119-60754	T STAND JUNCTION(WITH CASTER)	Tキヤクケツゴウ(キヤスタ-ツキ)	1
14		111-59366	T STAND JUNCTION	Tキヤクケツゴウ	(1)
15		GPF-06060000	PEDAL	ハダール	(1)
16		GPF-06070000	PEDAL MAT	ハダールマット	(1)
17		GPF-06080000	PEDAL ADJUSTING PLATE	フミイタ チョウセツハン	(1)
18		111-59001	PEDAL SHAFT BRACKET	フミイタ シクウケ	(2)
19		D8113-555-B00	PEDAL BUSHING	フミイタ フツユ	(2)
20		B8153-771-000	PEDAL CONNECTING ROD	ハダールツク	(1)
21		NM-6080001-SE	NUT M8	ロツカクナツト M8 1ツユ	(2)
22		SL-9082091-SE	WASHER HEXAGONAL BOLT	サカネツキロツカクホルト	(2)
23		WP-0871602-SE	WASHER 8.7X18X1.6	ヒラサカネ 8.7X18X1.6	(2)
24		SL-9061291-SE	WASHER HEXAGONAL BOLT M6 L=12	サカネツキロツカクホルト	(2)
25		B7114-012-0A0	MOTOR CONNECTING ROD ASM.	レンケツゴウ - ツキテクミ	1
26		111-51065	Z LEG JUNCTION (B)	Zキヤクケツゴウ(B)	1
27		B8151-771-0A0	PEDAL ASM.	Zキヤクケツゴウハダールクミ	1
28		SM-9082023-SE	SCREW M8 L=20	ロツカクホルト M8 L=20	(2)
29		WS-0861410-KR	SPRING WASHER 8.6X15X1.4	ハネサカネ 8.6X15X1.4	(2)
30		WP-0871602-SE	WASHER 8.7X18X1.6	ヒラサカネ 8.7X18X1.6	(4)
31		111-51909	PEDAL SHAFT BRACKET	フミイタ シクウケ	(2)
32		NM-6080721-SE	NUT M8	ロツカクナツト M8	(2)
33		D8113-555-B00	PEDAL BUSHING	フミイタ フツユ	(2)
34		SM-9061203-SE	SCREW M6 L=12	ロツカクホルト M6 L=12	(2)
35		WS-0621210-KR	SPRING WASHER 6.2X11.4X1.2	ハネサカネ 6.2X11.4X1.2	(2)
36		WP-0671016-SE	WASHER 6.7X13X1	ヒラサカネ 6.7X13X1	(2)
37		112-46600	PEDAL ADJUSTING PLATE	フミイタ チョウセツイタ	(1)
38		112-46501	PEDAL	ハダール	(1)
39		B8152-771-000	PEDAL MAT	ハダールマット	(1)
40		B8153-771-000	PEDAL CONNECTING ROD	ハダールツク	(1)

19. THREAD STAND COMPONENTS (FOR MO-6704S,MO-6714S)

糸立装置関係(MO-6704S,MO-6714S用)

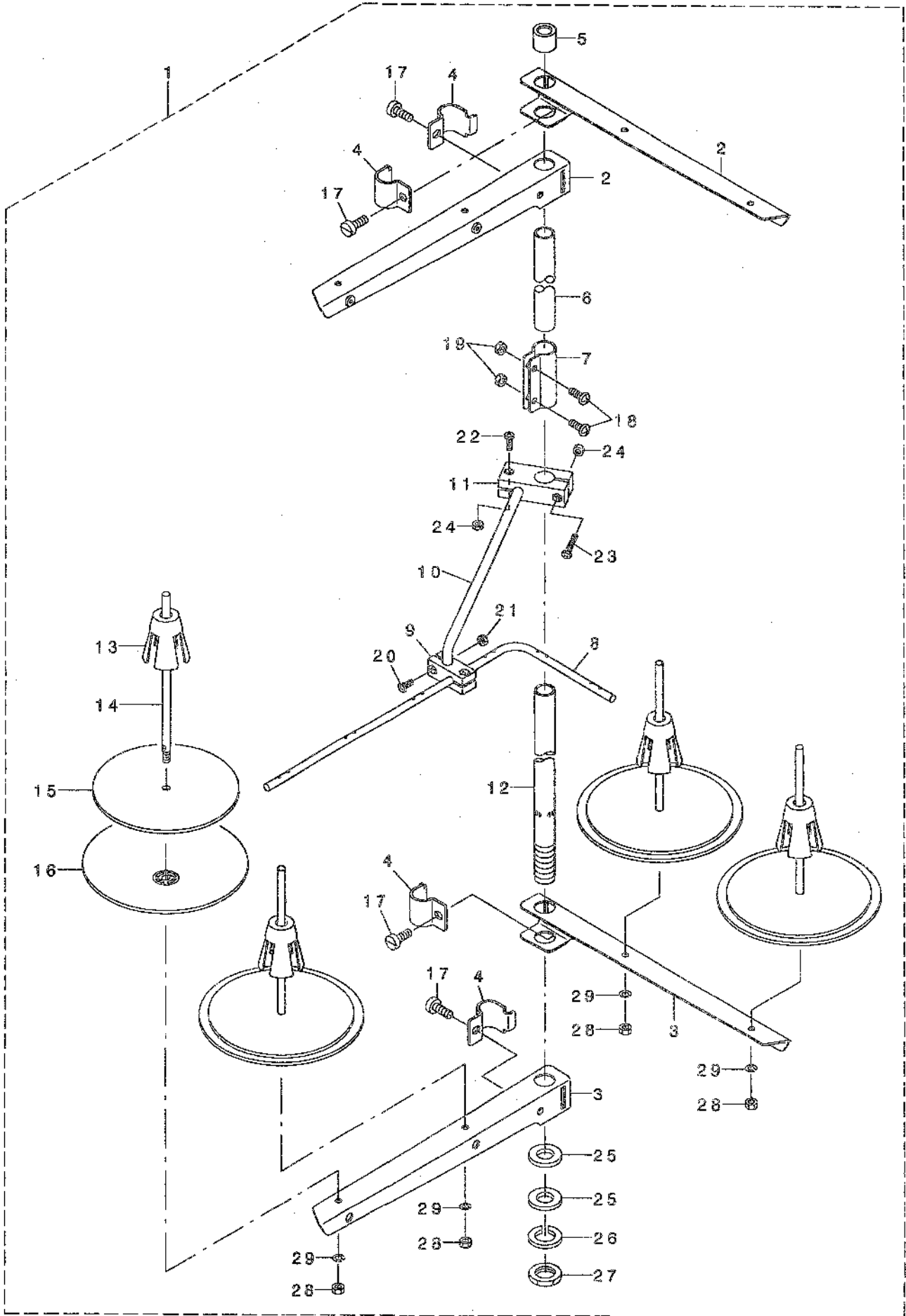

REF. NO	NOTE	PART NO.	DESCRIPTION	品名	Qty
1		131-67556	THREAD STANDING DEVICE ASM.	イトタテウチ(クミ)	1
2		229-30556	SPOOL REST ARM ASM.	イトタテウデ(クミ)	(2)
3		229-30507	SPOOL REST ARM	イトタテウデ	(2)
4		229-30706	THREAD GUIDE ARM JOINT	イトタテホ ウシメカナク	(4)
5		229-31406	THREAD STANDING ROD RUBBER CAP	イトタテホ ウホコ ゴム	(1)
6		229-30408	THREAD STANDING ROD, UPPER	イトタテホ ウ(ウエ)	(1)
7		229-31307	THREAD STANDING ROD JOINT	イトタテホ ウツキ テ	(1)
8		131-67903	THREAD STANDING THREAD GUIDE	イトタテイトアンナイ	(1)
9		131-68000	THREAD STANDING GUIDE BASE	イトタテイトアンナイ(シタ)タ イ	(1)
10		131-68109	THREAD STANDING GUIDE ARM	イトタテイトアンナイウデ	(1)
11		131-68208	THREAD STANDING GUIDE ARM BASE	イトタテイトアンナイウデ タ イ	(1)
12		229-30309	THREAD STANDING ROD, LOWER	イトタテホ ウ(シタ)	(1)
13		229-31108	SPOOL RETAINER	イトマキアレト メ	(4)
14		229-31000	SPOOL PIN	イトマキウケホ ウ	(4)
15		229-30903	SPOOL REST CUSHION	イトマキウケサ ラクツヨシ	(4)
16		229-30804	SPOOL REST	イトマキウケサ ラ	(4)
17		SM-6061610-SC	SCREW M6 L=16	ヒラコネツ M6 L=16	(4)
18		SM-4051405-SE	SCREW M5 L=14	ナハ コネツ M5 L=14	(2)
19		NM-6050001-SE	NUT M5	ロツカクナツ M5	(2)
20		SM-4041001-SC	SCREW M4X0.7 L=10	ナハ コネツ M4X0.7 L=10	(2)
21		NM-6040002-SE	NUT M4X0.7	ロツカクナツ M4X0.7 2ツ	(2)
22		SM-4041201-SC	SCREW M4 L=12	ナハ コネツ M4 L=12	(1)
23		SM-4042001-SC	SCREW M4 X 20	ナハ コネツ M4X0.7 L=20	(1)
24		NM-6040002-SE	NUT M4X0.7	ロツカクナツ M4X0.7 2ツ	(2)
25		WP-1612616-SE	WASHER 16X30X2.6	ヒラサ ガネ	(2)
26		WS-1643202-KR	SPRING WASHER	ハ ネサ ガネ 16.4X26.6X3.2	(1)
27		NM-6160511-SE	NUT M16X1.5	ロツカクナツ M16X1.5 1ツ	(1)
28		NM-6050001-SE	NUT M5	ロツカクナツ M5	(4)
29		WS-0510002-KN	SPRING WASHER	ハ ネサ ガネ 5.1X9.2X1.3	(4)

20. THREAD STAND COMPONENTS (MO-6704S, MO-6714S SPECIAL ORDER PARTS)

糸立装置関係(MO-6704S, MO-6714 特別注文部品)

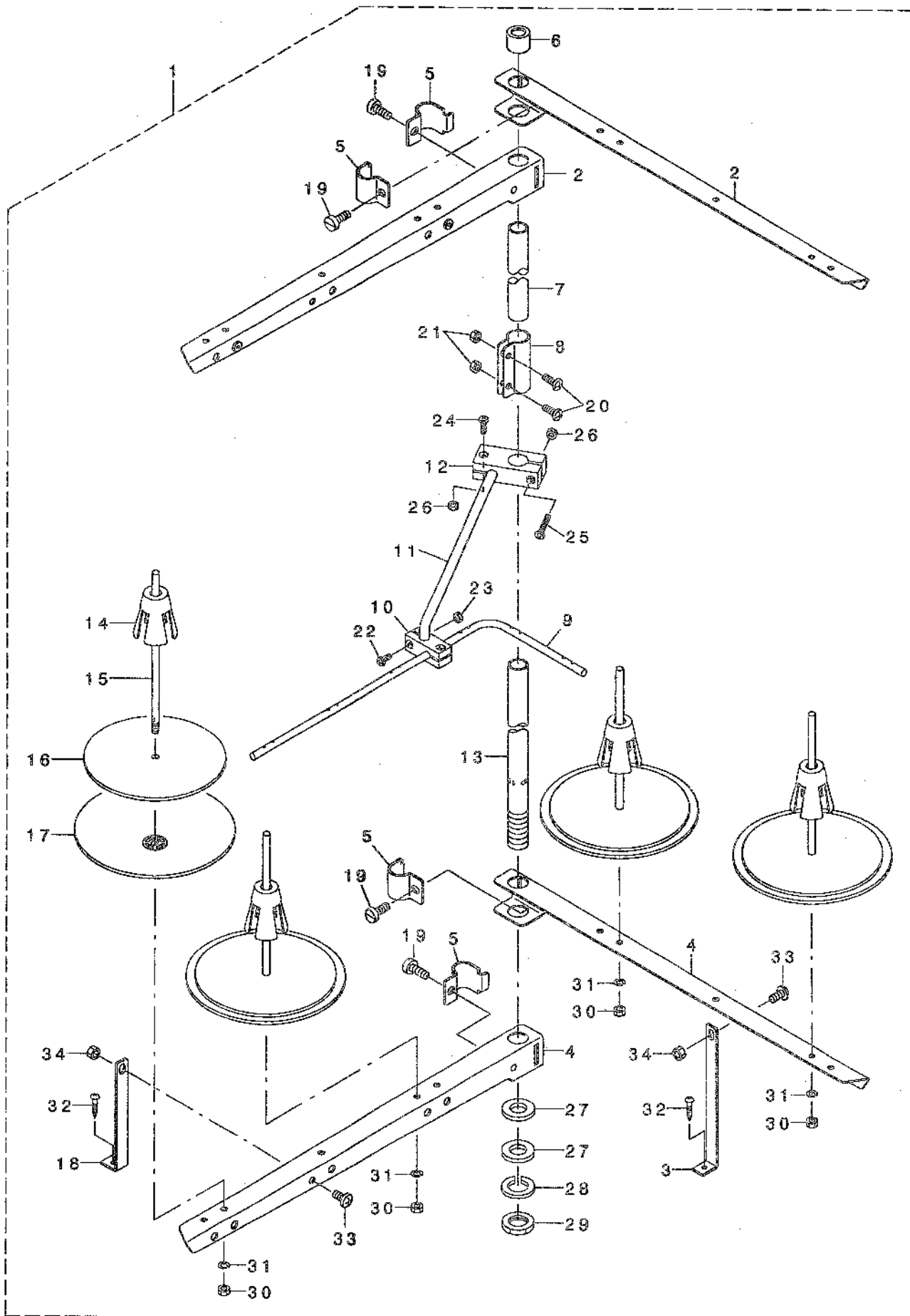

REF. NO	NOTE	PART NO.	DESCRIPTION	品名	Qty
1		131-67754	THREAD STANDING DEVICE ASM.	イトタテウチ(タミ)	1
2		131-68851	THREAD STANDING ARM ASM. ,LONG	イトタテウデ (チヨウ)タミ	(2)
3		131-68505	THREAD GUIDE ARM B	イトタテウデ ササエB	(1)
4		131-68802	THREAD STANDING ARM ,LONG	イトタテウデ チヨウ	(2)
5		229-30705	THREAD GUIDE ARM JOINT	イトタテホ ウツメカナク	(4)
6		229-31406	THREAD STANDING ROD RUBBER CAP	イトタテホ ウホゴ コ'ム	(1)
7		229-30408	THREAD STANDING ROD, UPPER	イトタテホ ウ(ウエ)	(1)
8		229-31307	THREAD STANDING ROD JOINT	イトタテホ ウツギ'テ	(1)
9		131-67903	THREAD GUIDE	イトタテイトアンナイ	(1)
10		131-68000	THREAD GUIDE BASE ,LOWER	イトタテイトアンナイ(シタ)タ'イ	(1)
11		131-68109	THREAD GUIDE ARM	イトタテイトアンナイウデ'	(1)
12		131-68208	THREAD GUIDE ARM BASE	イトタテイトアンナイウデ' タ'イ	(1)
13		229-30309	THREAD STANDING ROD, LOWER	イトタテホ ウ(シタ)	(1)
14		229-31109	SPOOL RETAINER	イトマキフレト'メ	(4)
15		229-31000	SPOOL PIN	イトマキウクホ'ウ	(4)
16		229-30903	SPOOL REST CUSHION	イトマキウクサ'ラクツツヨソ	(4)
17		229-30804	SPOOL REST	イトマキウクサ'ラ	(4)
18		131-68406	THREAD STANDING ARM SUPPORT, A	イトタテウデ' ササエA	(1)
19		SM-6061610-SC	SCREW M6 L=16	ヒラコネツ' M6 L=16	(4)
20		SM-4051405-SE	SCREW M5 L=14	ナ'コネツ' M5 L=14	(2)
21		NM-6050001-SE	NUT M5	ロツカクナツト M5	(2)
22		SM-4041001-SC	SCREW M4X0.7 L=10	ナ'コネツ' M4X0.7 L=10	(2)
23		NM-6040002-SE	NUT M4X0.7	ロツカクナツト M4X0.7 2ツ	(2)
24		SM-4041201-SC	SCREW M4 L=12	ナ'コネツ' M4 L=12	(1)
25		SM-4042001-SC	SCREW M4 X 20	ナ'コネツ' M4X0.7 L=20	(1)
26		NM-6040002-SE	NUT M4X0.7	ロツカクナツト M4X0.7 2ツ	(2)
27		WP-1612616-SE	WASHER 16X30X2.6	ヒラサ'カ'ネ	(2)
28		WS-1643202-KR	SPRING WASHER	ハ'ネサ'カ'ネ 16.4X26.6X3.2	(1)
29		NM-6160511-SE	NUT M16X1.5	ロツカクナツト M16X1.5 1ツ	(1)
30		NM-6050001-SE	NUT M5	ロツカクナツト M5	(4)
31		WS-0510002-KN	SPRING WASHER	ハ'ネサ'カ'ネ 5.1X9.2X1.3	(4)
32		SK-3382001-SE	SCREW D=3.8 L=20	マルモクネツ' D=3.8 L=20	(2)
33		SM-4061201-SE	SCREW M6 L=12	ナ'コネツ' M6 L=12	(2)
34		NM-6060001-SE	NUT M6	ロツカクナツト M6 1ツ	(2)

21. THREAD STAND COMPONENTS (FOR MO-6716S)

糸立装置関係(MO-6716S用)

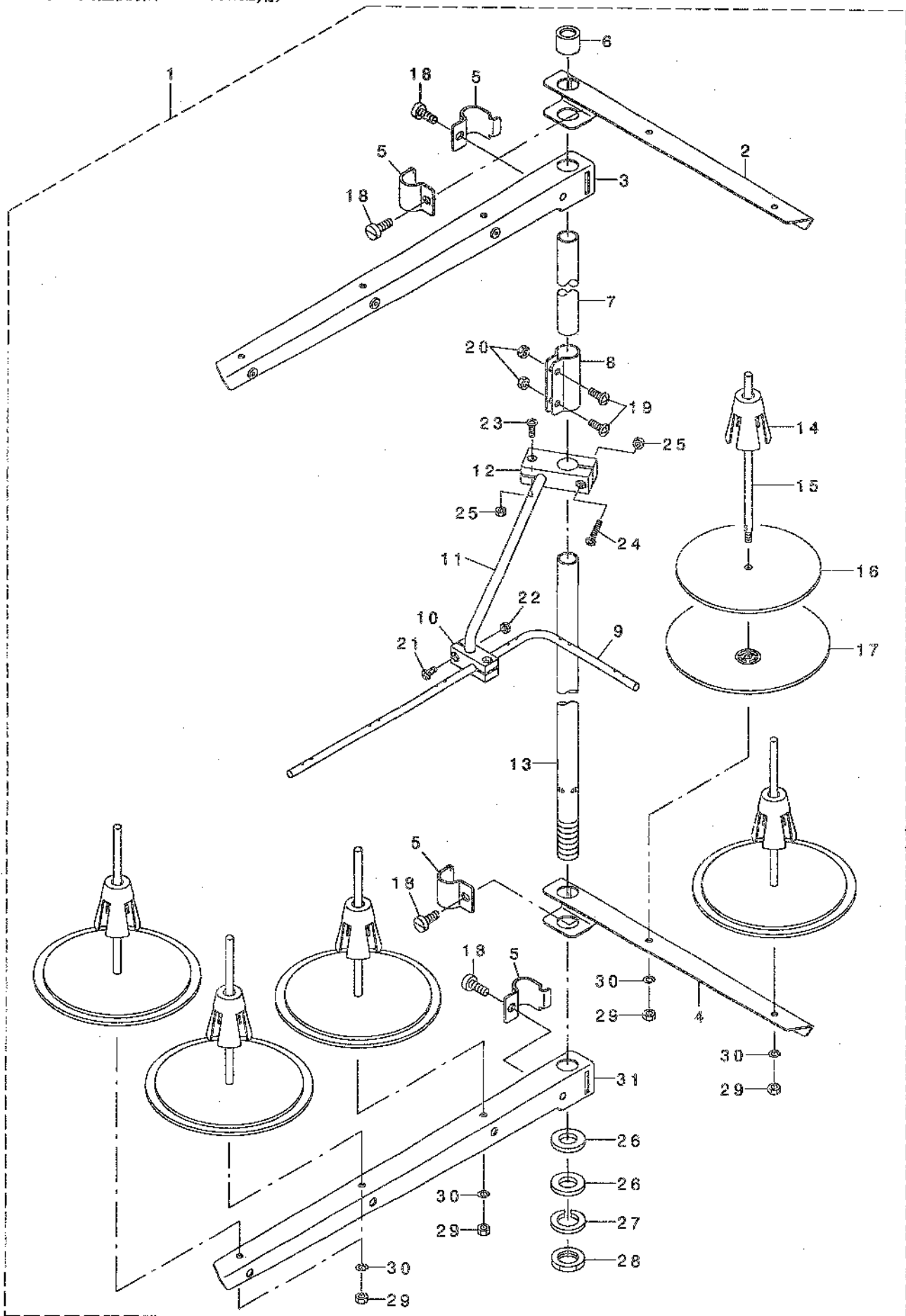

REF. NO	NOTE	PART NO.	DESCRIPTION	ヒョウメイ	Qty
1		131-67655	THREAD STANDING DEVICE ASM.	イトタテウチ(クミ)	1
2		229-30556	THREAD STANDING ARM ASM.	イトタテウテ(クミ)	(1)
3		131-68356	THREAD STANDING ARM ASM. ,LONG	イトタテウテ(チヨウ)クミ	(1)
4		229-30507	THREAD STANDING ARM	イトタテウテ	(1)
5		229-30705	THREAD GUIDE ARM JOINT	イトタテホウ ウツメカナダ	(4)
6		229-31406	THREAD STANDING ROD RUBBER CAP	イトタテホウ ウツメコ コノ ム	(1)
7		229-30408	THREAD STANDING ROD, UPPER	イトタテホウ ウ(ウエ)	(1)
8		229-31307	THREAD STANDING ROD JOINT	イトタテホウ ウツキ テ	(1)
9		131-67903	THREAD GUIDE	イトタテイトアンナイ	(1)
10		131-68000	THREAD GUIDE BASE, LOWER	イトタテイトアンナイ(シタ)タイ	(1)
11		131-68109	THREAD GUIDE ARM	イトタテイトアンナイウテ	(1)
12		131-68208	THREAD GUIDE ARM BASE	イトタテイトアンナイウテ タイ	(1)
13		229-30309	THREAD STANDING ROD, LOWER	イトタテホウ ウ(シタ)	(1)
14		229-31109	SPOOL RETAINER	イトマキアトメ ヌ	(5)
15		229-31000	SPOOL PIN	イトマキウケホウ ウ	(5)
16		229-30903	SPOOL REST CUSHION	イトマキウケホウ ラクツツヨソ	(5)
17		229-30804	SPOOL REST	イトマキウケホウ ラ	(5)
18		SM-6061610-SC	SCREW M6 L=16	ヒラコネジ M6 L=16	(4)
19		SM-4051405-SE	SCREW M5 L=14	ナハコネジ M5 L=14	(2)
20		NM-6050001-SE	NUT M5	ロツカクナツト M5	(2)
21		SM-4041001-SC	SCREW M4X0.7 L=10	ナハコネジ M4X0.7 L=10	(2)
22		NM-6040002-SE	NUT M4X0.7	ロツカクナツト M4X0.7 2ツユ	(2)
23		SM-4041201-SC	SCREW M4 L=12	ナハコネジ M4 L=12	(1)
24		SM-4042001-SC	SCREW M4 X 20	ナハコネジ M4X0.7 L=20	(1)
25		NM-6040002-SE	NUT M4X0.7	ロツカクナツト M4X0.7 2ツユ	(2)
26		WP-1612616-SE	WASHER 16X30X2.6	ヒラサガネ	(2)
27		WS-1643202-KR	SPRING WASHER	ハネサガネ 16.4X26.6X3.2	(1)
28		NM-6160511-SE	NUT M16X1.5	ロツカクナツト M16X1.5 1ツユ	(1)
29		NM-6050001-SE	NUT M5	ロツカクナツト M5	(5)
30		WS-0510002-KN	SPRING WASHER	ハネサガネ 5.1X9.2X1.3	(5)
31		131-68307	THREAD STANDING ARM ,LONG	イトタテウテ(チヨウ)	(1)

22. THREAD STAND COMPONENTS (MO-6716S SPECIAL ORDER PARTS)

糸立装置関係(MO-6716S 特別注文部品)

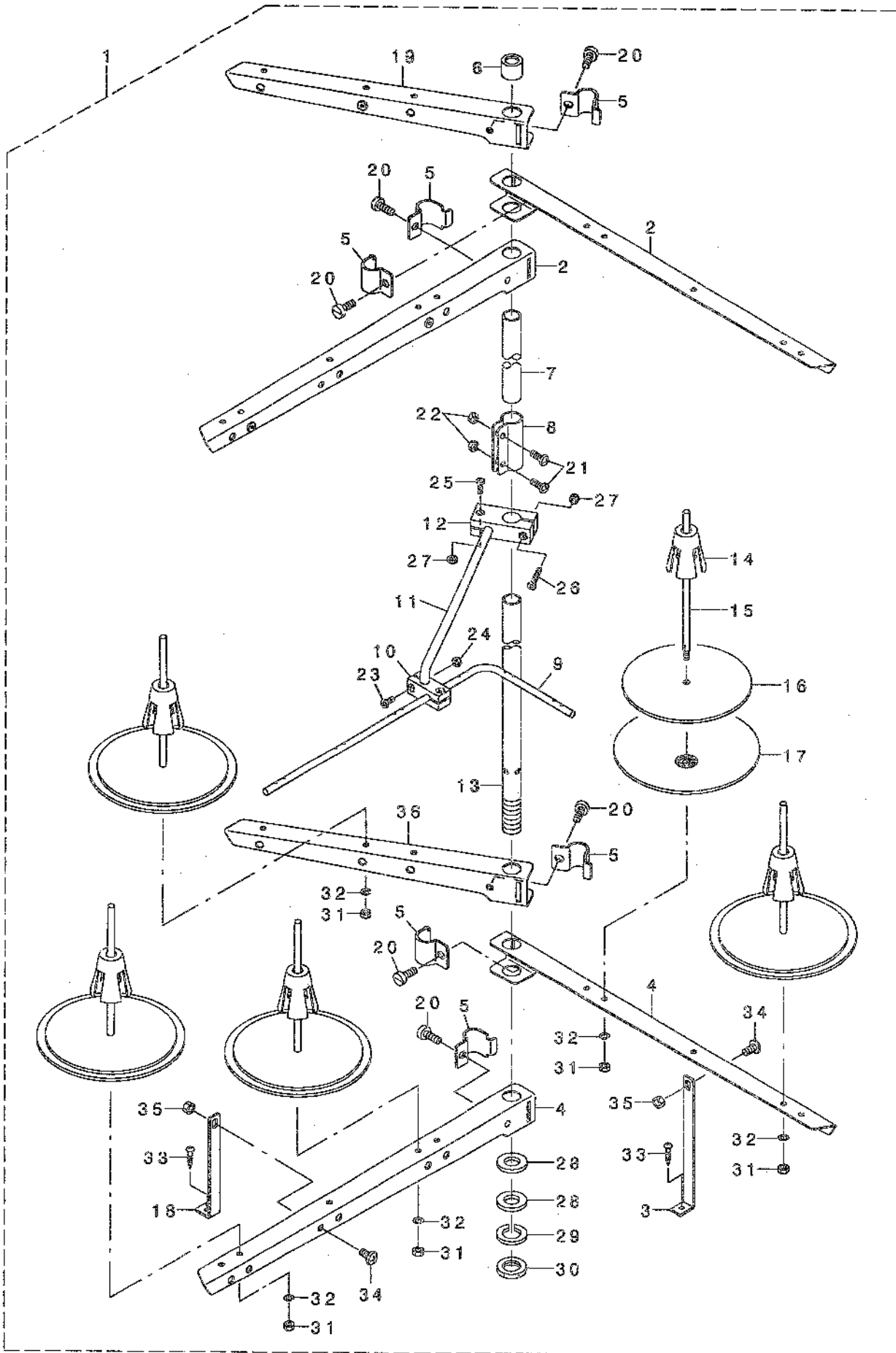

REF. NO	NOTE	PART NO.	DESCRIPTION	ヒヨメイ	Qty
1		131-67853	THREAD STANDING DEVICE ASM.	イトタテソウチ(クミ)	1
2		131-68851	THREAD STANDING ARM ASM. ,LONG	イトタテウデ (チヨウ)クミ	(2)
3		131-68505	THREAD STANDING ARM SUPPORT B	イトタテウデ ササエB	(1)
4		131-68802	THREAD STANDING ARM ,LONG	イトタテウデ チヨウ	(2)
5		229-30705	THREAD GUIDE ARM JOINT	イトタテホ ウツメカナゲ	(6)
6		229-31406	THREAD STANDING ROD RUBBER CAP	イトタテホ ウホコ コム	(1)
7		229-30408	THREAD STANDING ROD, UPPER	イトタテホ ウ(ウエ)	(1)
8		229-31307	THREAD STANDING ROD JOINT	イトタテホ ウツキ テ	(1)
9		131-67903	THREAD STANDING THREAD GUIDE	イトタテイトアンナイ	(1)
10		131-68000	THREAD GUIDE BASE, LOWER	イトタテイトアンナイ(シタ)タ イ	(1)
11		131-68109	THREAD GUIDE ARM BASE	イトタテイトアンナイウデ	(1)
12		131-68208	THREAD GUIDE ARM BASE	イトタテイトアンナイウデ タ イ	(1)
13		229-30309	THREAD STANDING ROD, LOWER	イトタテホ ウ(シタ)	(1)
14		229-31109	SPCOL RETAINER	イトマキフレト ム	(5)
15		229-31000	SPOOL PIN	イトマキウホウ ウ	(5)
16		229-30903	SPOOL REST CUSHION	イトマキウケサ ラクツシヨソ	(5)
17		229-30804	SPOOL REST	イトマキウケサ ラ	(5)
18		131-68406	THREAD STANDING ARM SUPPORT A	イトタテウデ ササエA	(1)
19		131-68950	THREAD STANDING ARM A ASM.	イトタテウデ Aクミ	(1)
20		SM-6061610-SC	SCREW M6 L=16	ヒラコネツ M6 L=16	(6)
21		SM-4051405-SE	SCREW M5 L=14	ナハ コネツ M5 L=14	(2)
22		NM-6050001-SE	NUT M5	ロツカクナツト M5	(2)
23		SM-4041001-SC	SCREW M4X0.7 L=10	ナハ コネツ M4X0.7 L=10	(2)
24		NM-6040002-SE	NUT M4X0.7	ロツカクナツト M4X0.7 2ツユ	(2)
25		SM-4041201-SC	SCREW M4 L=12	ナハ コネツ M4 L=12	(1)
26		SM-4042001-SC	SCREW M4 X 20	ナハ コネツ M4X0.7 L=20	(1)
27		NM-6040002-SE	NUT M4X0.7	ロツカクナツト M4X0.7 2ツユ	(2)
28		WP-1612616-SE	WASHER 16X30X2.6	ヒラサ ガ ネ	(2)
29		WS-1643202-KR	SPRING WASHER	ハ ネサ ガ ネ 16.4X26.6X3.2	(1)
30		NM-6160511-SE	NUT M16X1.5	ロツカクナツト M16X1.5 1ツユ	(1)
31		NM-6050001-SE	NUT M5	ロツカクナツト M5	(5)
32		WS-0510002-KN	SPRING WASHER	ハ ネサ ガ ネ 5.1X9.2X1.3	(5)
33		SK-3382001-SE	SCREW D=3.8 L=20	マルモクネツ D=3.8 L=20	(2)
34		SM-4061201-SE	SCREW M6 L=12	ナハ コネツ M6 L=12	(2)
35		NM-6060001-SE	NUT M6	ロツカクナツト M6 1ツユ	(2)
36		131-68901	THREAD STANDING ARM A	イトタテウデ A	(1)

23. SPECIAL ORDER PARTS COMPONENTS

特別注文部品関係

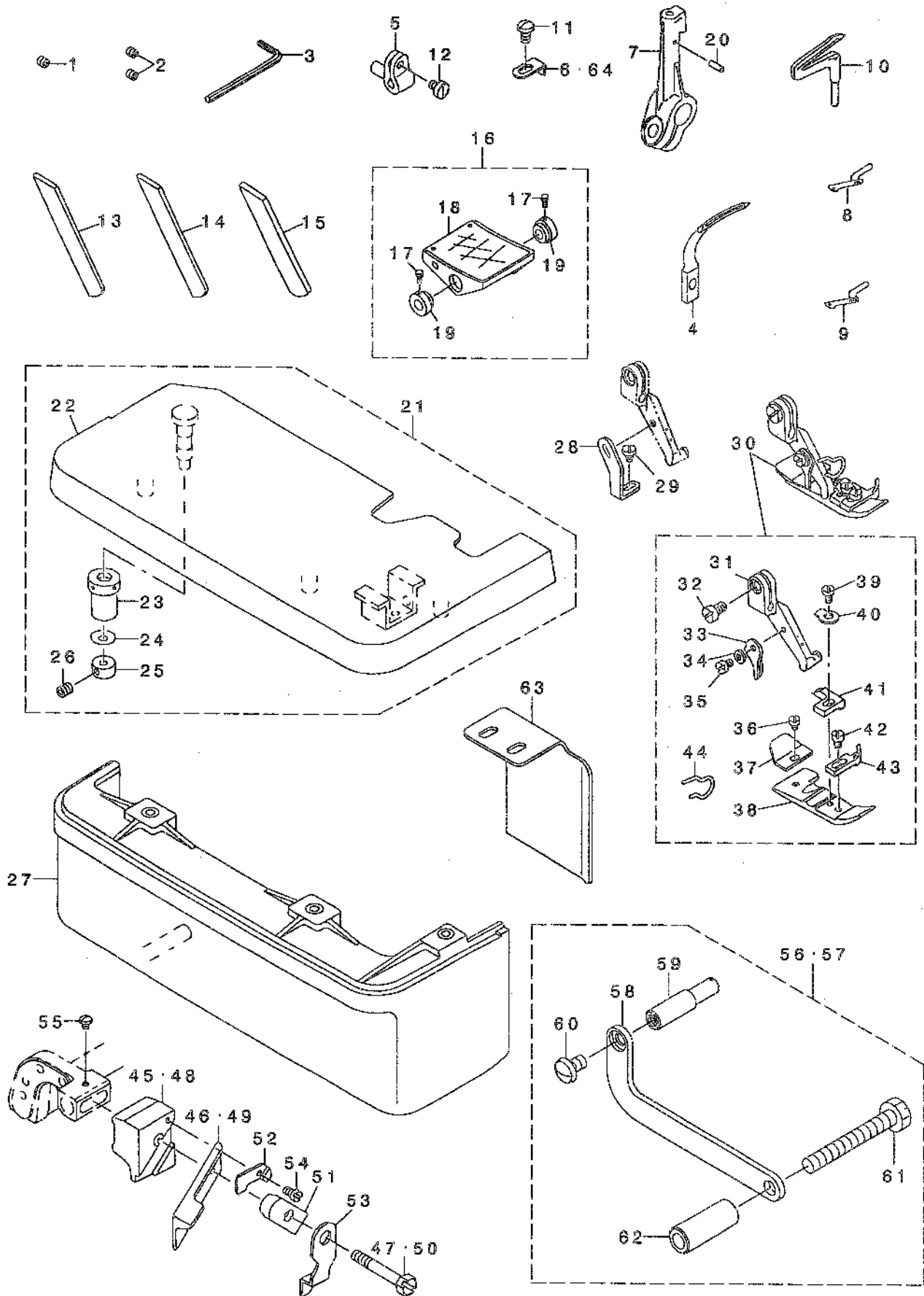

REF. NO	NOTE	PART NO.	DESCRIPTION	品名	Qty
1	01	SS-8080322-TP	SCREW 1/8-44 L=3.2	トメネジ 1/8-44 L=3.2	1
2	02	SS-8080322-TP	SCREW 1/8-44 L=3.2	トメネジ 1/8-44 L=3.2	2
3		B9112-804-000	SPANNER	ハサトメネジ スパナ	1
4	*05	121-20713	CHAIN LOOPER	ニジ ユウカンル-ハ-	1
5		115-44707	UPPER LOOPER SUPPORT ARM	ウツル-ハ ヲウ ヲデ	1
6	01	118-98103	PRESSER FOOT AUXILIARY PLATE	オサエネジ ヨイタ	1
7		121-23709	LOWER LOOPER SUPPORT ARM	シタル-ハ- ヲウ ヲデ	1
8	03	B2519-804-000	UPPER LOOPER	ウツル-ハ	1
9	04	B2519-814-000	UPPER LOOPER	ウツル-ハ	1
10		B2521-804-000	LOWER LOOPER	シタル-ハ	1
11	01	SS-4080620-TP	SCREW 1/8-44 L=6	ナメネジ 1/8-44 L=6	1
12		SS-6080410-SP	SCREW 1/8-44 L=4	ヒラネジ 1/8-44 L=4	1
13		118-47605	LOWER KNIFE	チヨウコウ シタメス	1
14		119-84509	CERAMIC LOWER KNIFE	セラミック シタメス	1
15		119-92005	LOWER KNIFE	シタメス	1
16		119-66763	PEDAL ASM.	ペダル (クミ)	1
17		SM-9061203-SE	SCREW M6 L=12	ロツカクホ ネト M6 L=12	(2)
18		119-65704	PEDAL	ペダル	(1)
19		119-65803	PEDAL THRUST COLLAR	ペダル 軸サエウデ	(2)
20		PS-0200062-KH	SPRING PIN 2X6	スプリング ピン 2X6	1
21	05	121-05458	CLOTH PLATE ASM.	ヌノダ イケツゴウ	1
22		121-04550	CLOTH PLATE ASM.	ヌノダ イケツミ	(1)
23		115-01301	ECCENTRIC BUSHING	ヌノダ イハンソノア ツシユ	(1)
24		WZ-0420350-KP	DISC SPRING	ディスク スプリング	(1)
25		CS-0400671-SD	THRUST HOLDER	スラストホルダ	(1)
26		SM-8040302-TP	SETSCREW	トメネジ	(1)
27	05	119-49164	CLOTH BASE COVER	ヌノダ イカハ-	1
28	01	B1539-804-000	PRESSER FOOT FIXING PLATE	オサエ ヲサエイタ	1
29	01	SS-6060410-TP	SCREW 3/32-56 L= 3.5	ヒラネジ 3/32-56 L=3.5	1
30	04	121-52468	PRESSER FOOT., (FINGER GUARD).	オサエケツゴウ ヲ(エビ) ガ-ト ツキ	1
31		118-72009	PRESSER FOOT HINGE	オサエヒンジ	(1)
32		SS-6090670-TP	SCREW 9/64-40 L=6	ヒラネジ 9/64-40 L=6	(1)
33		B1530-804-000	STOPPER	オサエ ストッパ-	(1)
34		WP-0250516-SD	WASHER 2.5X6X0.5	ヒラネジ ガネ 2.5X6X0.5	(1)
35		SS-7060610-SP	SCREW 3/32-56 L= 5.5	マルヒラネジ 3/32-56 L=5.5	(1)
36		SS-6060210-SP	SCREW 3/32-56 L= 1.9	ヒラネジ 3/32-56 L=1.9	(1)
37		B1511-814-000	REAR PRESSER FOOT	カタカントメ	(1)
38		B1507-814-00P	PRESSER FOOT	オサエ	(1)
39		SS-7080520-SP	SCREW 1/8-44 L=4.9	マルヒラネジ 1/8-44 L=4.9	(1)
40		B1508-804-00B	SPRING	オサエ トリツケガネ	(1)
41		121-60008	STITCH TONGUE	イト スパナ ヲサエ	(1)
42		SS-6060440-TP	SCREW 3/32-56 L=3.5	ヒラネジ	(1)
43		B1510-814-000	CURL GUARD	カーネツミ	(1)
44		131-78306	FINGER GUARD	エビ ガ-ト	(1)
45	01	115-98000	UPPER KNIFE SUPPORT	ウツメスサエ	1
46	01	118-45807	UPPER KNIFE	ウツメス	1
47	01	SS-9111810-SP	SCREW 11/64-40 L=16	ロツカクホ ネト 11/64-40 L=16	1
48	05	118-45500	UPPER KNIFE SUPPORT	ウツメスサエ	1
49	05	118-45906	UPPER KNIFE	ウツメス	1
50	05	SS-9112310-SP	SCREW 11/64-40 L=23	ロツカクホ ネト 11/64-40 L=23	1
51	05	115-65504	UPPER KNIFE PRESSER PLATE	ウツメスサエ	1
52		115-65702	WASHER	ウツメスサエ ガネ	1
53		118-48405	UPPER KNIFE COVER	ウツメスカハ-	1
54		SS-4060310-SP	SCREW 3/32-56 L=2.5	ナメネジ 3/32-56 L=2.5	1
55		SS-4060310-SP	SCREW 3/32-56 L=2.5	ナメネジ 3/32-56 L=2.5	1
56		400-25294	SYNCHRONIZER STOPPER ASM.	シンクロナイザ-マフリト メカニ(SY-1)	1
57	*	400-11755	SYNCHRONIZER TURN STOPPER ASM	シンクロナイザ-マフリト メカニ	1
58		400-11757	SYNCHRONIZER STOPPER BASE	シンクロナイザ-マフリト メトリックイタ	(1)
59		400-22255	SYNCHRONIZER STOPPER	シンクロナイザ-ストッパ-	(1)
60		SS-5120810-SP	SCREW	ハ イント ネジ	(1)
61		SS-9154540-SP	SCREW 15/64-28 L=45	ロツカクホ ネト 15/64-28 L=45	(1)
62		400-11758	SYNCHRONIZER BASE COLLAR	シンクロトリツケイタカラ	(1)
63	*	400-36778	V BELT SLIDER	ベネツト スライダ-	1
64	*04	400-30533	PRESSER FOOT AUXILIARY PLATE	オサエネジ ヲイタ	1

NOTE (注記)

- 01... FOR MO-6704S MO-6704S用
- 02... FOR MO-6714S, MO-6716S MO-6714S, MO-6716S用
- 03... FOR MO-6704S, MO-6716S MO-6704S, MO-6716S用
- 04... FOR MO-6714S MO-6714S用
- 05... FOR MO-6716S MO-6716S用

24. ACCESSORIES PARTS COMPONENTS

付属品関係

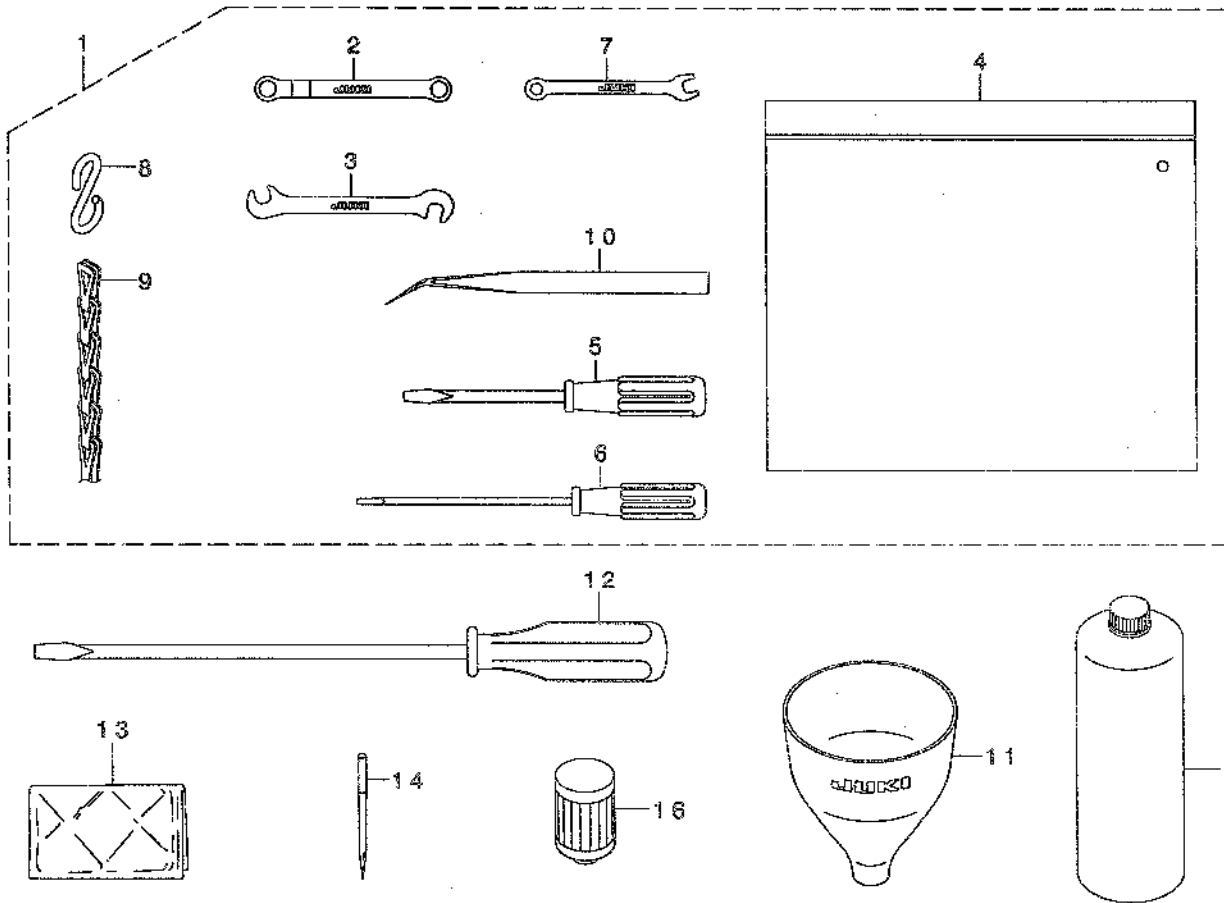

REF. NO	NOTE	PART NO.	DESCRIPTION	ル ヴ ェ イ	Qty
1		131-60858	ACCESSORIE BAG ASM.	アソ クレソバ ック (クミ)	1
2		131-60007	RING SPANNER	メカ ネレンチ(7X7)	(1)
3		131-60205	PIN SPANNER	シュオクリウデ ビ ソスパ ナ	(1)
4		229-32800	ACCESSORIE BAG	アソ クレソバ ック	(1)
5		229-33105	SCREW DRIVER, MIDDLE	ド ライバ - (チユウ)	(1)
6		123-47308	SCREW DRIVER (SMALL)	ド ライバ - (ショウ)	(1)
7		131-60106	SPANNER (5X6)	スパ ナ(5X6)	(1)
8		131-60304	S SHAPED HOOK	Sガ タカナク	(2)
9		131-60403	CHAIN	クサリ	(1)
10		122-88403	TWEEZERS	ピンセット	(1)
11		131-60601	FUNNEL	シ ョ-ゴ	1
12		229-33006	SCREW DRIVER, LARGE	ド ライバ - (タ イ)	1
13		229-33303	VINYL COVER	トウア ビ ニ-ルカバー	1
14		MDC-270B1104	NEEDLE DCX27 #11-4EA.	ハリ DCX27 #11-4	1
15		MML-018900CA	JUKI MACHINE OIL 18	JUKI MACHINE OIL 18	1
16		131-42500	CARTRIDGE FILTER	カートリッジ フィルタ	1

NUMERICAL INDEX OF PARTS

索引

PART NO 品番	PAGE 頁	REF NO	PART NO 品番	PAGE 頁	REF NO	PART NO 品番	PAGE 頁	REF NO	PART NO 品番	PAGE 頁	REF NO
BP-3000001-OR	26	24	NM-6040002-SE	32	21	SM-4040655-SP	2	31	SS-2080520-SL	2	4
BP-3000001-OR	26	62	NM-6040002-SE	32	24	SM-4040655-SP	14	30	SS-2110910-SL	22	4
B1211-804-000	6	16	NM-6040002-SE	34	23	SM-4040855-SP	2	9	SS-3080610-SP	2	6
B1211-804-000	6	18	NM-6040002-SE	34	26	SM-4040855-SP	2	43	SS-3090610-SP	14	32
B1212-704-000	6	17	NM-6040002-SE	36	22	SM-4040855-SP	4	3	SS-3080610-SP	14	51
B1215-804-000	6	21	NM-6040002-SE	36	25	SM-4040855-SP	4	14	SS-4060310-SP	40	54
B1507-804-000	18	12	NM-6040002-SE	38	24	SM-4040855-SP	6	26	SS-4060310-SP	40	55
B1507-814-00P	18	27	NM-6040002-SE	38	27	SM-4040855-SP	8	32	SS-4080620-TP	12	2
B1507-814-00P	40	38	NM-6050001-SE	32	19	SM-4040855-SP	8	41	SS-4080620-TP	15	36
B1508-804-00B	18	14	NM-6050001-SE	32	28	SM-4040855-SP	12	15	SS-4080620-TP	18	28
B1508-804-00B	18	29	NM-6050001-SE	34	21	SM-4040855-SP	12	35	SS-4080620-TP	40	11
B1508-804-00B	40	40	NM-6050001-SE	34	30	SM-4040855-SP	24	5	SS-4080415-SP	20	45
B1509-804-000	18	15	NM-6050001-SE	36	20	SM-4041001-SC	32	20	SS-4080415-SP	20	46
B1509-814-00P	18	30	NM-6050001-SE	36	29	SM-4041001-SC	34	22	SS-4080415-SP	20	47
B1510-814-000	18	17	NM-6050001-SE	38	22	SM-4041001-SC	36	21	SS-4080415-SP	20	48
B1510-814-000	18	32	NM-6050001-SE	38	31	SM-4041001-SC	38	23	SS-4080515-SP	12	27
B1510-814-000	40	43	NM-6060001-SE	34	34	SM-4041055-SP	2	17	SS-4080615-SP	14	49
B1511-814-000	18	11	NM-6060001-SE	38	35	SM-4041055-SP	12	60	SS-4091015-SP	2	14
B1511-814-000	18	26	NM-6060003-SC	16	25	SM-4041201-SC	32	22	SS-4091015-SP	24	13
B1511-814-000	40	37	NM-6080001-SE	30	9	SM-4041201-SC	34	24	SS-4091015-SP	24	22
B1513-816-000	18	39	NM-6080001-SE	30	21	SM-4041201-SC	36	23	SS-4110515-SP	5	33
B1514-816-000	18	45	NM-6080600-SM	28	29	SM-4041201-SC	38	25	SS-4110515-SP	20	49
B1530-804-000	18	7	NM-6080721-SE	30	32	SM-4041455-SM	10	27	SS-4110615-SP	20	30
B1530-804-000	18	22	NM-6160511-SE	32	27	SM-4042001-SC	32	23	SS-4112215-SP	26	13
B1530-804-000	40	33	NM-6160511-SE	34	29	SM-4042001-SC	34	25	SS-4120615-SP	2	12
B1539-804-000	40	28	NM-6160511-SE	36	28	SM-4042001-SC	36	24	SS-4151215-SP	4	18
B1620-804-000	10	43	NM-6160511-SE	38	30	SM-4042001-SC	38	26	SS-5080212-TP	6	3
B2119-816-A00	15	27	NS-6090310-SN	2	5	SM-4050855-SP	6	7	SS-5090610-SP	27	11
B2119-816-B00	15	28	NS-6090310-SP	27	12	SM-4050855-SP	20	44	SS-5090610-SP	28	23
B2119-816-C00	15	29	NS-6090310-SP	28	24	SM-4050855-SP	26	28	SS-5110710-SP	4	31
B2119-816-D00	15	30	NS-6110310-SP	26	32	SM-4051055-SP	22	8	SS-5110710-SP	27	17
B2119-816-E00	15	31	NS-6110310-SP	26	52	SM-4051255-SP	4	7	SS-5110710-SP	28	3
B2202-816-000	20	39	NS-6110420-SP	2	46	SM-4051255-SP	12	25	SS-5110710-SP	28	38
B2519-804-000	40	8	NS-6110420-SP	16	26	SM-4051405-SE	32	18	SS-5120810-SP	40	60
B2519-814-000	40	9	NS-6240630-SE	27	23	SM-4051405-SE	34	20	SS-5150510-SP	20	50
B2521-804-000	40	10	NS-6240630-SE	28	40	SM-4051405-SE	36	19	SS-6060210-SP	18	10
B3534-352-000	26	7	NS-6620320-SP	10	40	SM-4051405-SE	38	21	SS-6060210-SP	18	25
B7114-012-0A0	30	25	NS-6680410-SP	4	27	SM-4051601-SC	26	35	SS-6060210-SP	40	36
B8151-771-0A0	30	27				SM-4060801-SE	26	64	SS-6060340-SP	18	44
B8152-771-000	30	39	PS-0200052-KH	20	28	SM-4061201-SE	34	33	SS-6060410-TP	40	29
B8153-771-000	30	8	PS-0200062-KH	40	20	SM-4061201-SE	38	34	SS-6060440-TP	14	18
B8153-771-000	30	20	PS-0250062-KH	15	32	SM-6040600-SP	12	22	SS-6060440-TP	18	16
B8153-771-000	30	40	PS-0300062-KH	14	16	SM-6061202-TP	10	34	SS-6060440-TP	18	31
B9112-804-000	40	3	PS-0300142-KH	16	16	SM-6051202-TP	15	2	SS-6060440-TP	40	42
						SM-6051202-TP	15	14	SS-6080320-SP	10	15
CM-3002000-A1	4	17	RE-0300000-KO	12	37	SM-6061200-SP	14	23	SS-6080340-SP	12	55
CM-3002000-01	2	40	RE-0300000-KO	16	47	SM-6061200-SP	16	27	SS-6080340-SP	16	17
CM-3002001-B1	4	36	RE-0500000-KO	12	41	SM-6061202-TP	6	33	SS-6080410-SP	14	28
CQ-2000000-00	8	44	R4200-J6E-D00	22	1	SM-6061202-TP	6	37	SS-6080410-SP	40	12
CQ-2000000-00	14	57	R4305-J6E-E00	22	2	SM-6061402-TP	8	3	SS-6080720-SP	8	23
CQ-2020000-00	8	58	R4508-J6E-D00	22	3	SM-6061402-TP	8	8	SS-6081210-TP	6	42
CQ-2020000-00	14	58				SM-6061402-TP	10	6	SS-6090420-SP	28	11
CQ-2520000-00	8	60	SB-1100003-00	6	22	SM-6061402-TP	23	3	SS-6090620-TP	12	8
CS-0400671-SD	40	25	SD-0280401-SL	8	61	SM-6061610-SC	32	17	SS-6090620-TP	14	65
CS-111101H-SH	23	21	SD-0600341-TP	20	42	SM-6061610-SC	34	19	SS-6090620-TP	15	37
CS-1111019-SH	23	22	SD-0640241-SP	16	15	SM-6061610-SC	36	18	SS-6090630-TP	14	12
			SD-0720271-SP	12	59	SM-6061610-SC	38	20	SS-6090630-TP	27	27
D8113-555-B00	30	7	SD-0720803-TH	15	33	SM-6061802-TP	26	21	SS-6090630-TP	28	37
D8113-555-B00	30	19	SK-2351600-SC	27	18	SM-8040302-TP	2	39	SS-6090670-TP	8	37
D8113-555-B00	30	33	SK-2351600-SC	27	24	SM-8040302-TP	40	26	SS-6090670-TP	18	6
D8204-555-D00	27	22	SK-2351600-SC	28	4	SM-8040402-TP	16	39	SS-6090670-TP	18	21
D8204-555-D00	28	34	SK-3311500-SC	27	25	SM-8050412-TP	26	5	SS-6090670-TP	18	36
			SK-3311500-SC	28	35	SM-8050502-TP	26	42	SS-6090670-TP	40	32
EA-9500B01-00	8	18	SK-3382001-SE	34	32	SM-9061203-SE	30	34	SS-6090810-SP	26	14
			SK-3382001-SE	38	33	SM-9061203-SE	40	17	SS-6110610-TP	22	6
GPF-06060000	30	3	SK-3412001-SE	4	40	SM-9082023-SE	30	28	SS-6110610-TP	22	17
GPF-06060000	30	15	SK-3513200-SC	27	26	SM-9082513-CF	28	28	SS-6110710-TP	15	35
GPF-06070000	30	4	SK-3513200-SC	28	31	SQ-0000451-MZ	26	63	SS-6110710-TP	15	38
GPF-06070000	30	16	SL-9061291-SE	30	12	SQ-1110401-MZ	26	15	SS-6110710-TP	16	5
GPF-06080000	30	5	SL-9061291-SE	30	24	SQ-1110451-MZ	26	31	SS-6111040-SP	23	8
GPF-06080000	30	17	SL-9082091-SE	30	10	SQ-1110451-MZ	26	36	SS-6111440-SP	2	47
			SL-9082091-SE	30	22	SQ-1110451-MZ	26	53	SS-6111610-SP	23	10
MDC-270B1100	8	53	SM-1040801-SC	2	10	SQ-1150441-SD	26	50	SS-6121020-SP	16	40
MDC-270B1100	8	65	SM-1040801-SC	4	4	SQ-1150451-MZ	26	37	SS-6121020-SP	26	46
MDC-270B1104	41	14	SM-1040801-SC	4	13	SQ-1150454-SD	26	26	SS-6121220-TP	10	3
MML-018900CA	41	15	SM-4030455-SP	12	16	SS-1060610-SP	12	20	SS-6151440-SP	22	34

NUMERICAL INDEX OF PARTS

索引

PART NO 品番	PAGE 頁	REF NO	PART NO 品番	PAGE 頁	REF NO	PART NO 品番	PAGE 頁	REF NO	PART NO 品番	PAGE 頁	REF NO
SS-6661110-SP	12	46	SS-9151210-TP	14	22	115-65504	40	51	121-56907	18	48
SS-7060310-SP	12	12	SS-9151210-TP	15	8	115-65702	40	52	121-60008	40	41
SS-7060310-SP	26	49	SS-9151210-TP	16	6	115-66809	23	12	121-62232	18	41
SS-7060510-SP	18	3	SS-9154540-SP	40	61	115-98000	40	45	121-64802	18	37
SS-7060510-SP	22	43	SS-9681610-TP	6	12	118-02006	22	32	121-67409	18	40
SS-7060610-SP	14	54	ST-6030821-OA	28	12	118-06304	22	12	121-67508	18	43
SS-7060610-SP	18	9	ST-6030821-OA	28	13	118-40303	26	8	121-67607	18	42
SS-7060610-SP	18	24				118-45500	40	48	121-67706	18	46
SS-7060610-SP	40	35	TA-0400301-MO	26	41	118-45807	40	46	121-67805	18	38
SS-7080520-SP	18	13	TA-0800504-RO	12	53	118-45906	40	49	121-76004	14	15
SS-7080520-SP	40	39	TA-0950806-RO	24	4	118-46607	22	14	121-77903	22	41
SS-7090510-SP	22	42	TA-1030402-RO	10	7	118-46805	22	28	122-53829	18	1
SS-7090530-SP	2	20	TA-1871602-RO	4	41	118-46805	22	33	122-56905	8	63
SS-7090610-SP	2	22	TA-2050416-RO	10	8	118-47605	40	13	122-57002	8	64
SS-7090610-SP	22	44	TA-2050805-RO	4	42	118-48405	40	53	122-88403	41	10
SS-7090610-SP	24	10				118-72009	18	5	122-88700	16	33
SS-7090610-SP	24	19	WP-0250516-SD	18	8	118-72009	18	20	122-88908	22	7
SS-7090611-SL	4	34	WP-0250516-SD	18	23	118-72009	40	31	123-15909	26	3
SS-7090710-SP	22	25	WP-0250516-SD	40	34	118-76166	18	4	123-16006	26	10
SS-7090850-SP	14	26	WP-0370316-SD	23	20	118-76869	18	19	123-16105	26	11
SS-7091410-SP	2	33	WP-0370316-SD	28	14	118-88104	14	14	123-17004	26	9
SS-7110510-SP	2	27	WP-0371016-SD	12	28	118-90001	14	1	123-40303	14	31
SS-7110510-SP	16	14	WP-0371026-SD	24	14	118-90100	22	37	123-40402	14	33
SS-7110710-SL	20	29	WP-0371026-SD	24	23	118-90308	22	38	123-40501	14	48
SS-7110710-SP	2	29	WP-0460556-SD	12	61	118-98103	40	6	123-40600	14	25
SS-7110720-SP	22	13	WP-0460556-SD	16	46	119-18109	26	6	123-40709	14	27
SS-7110720-TP	15	39	WP-0480856-SP	12	62	119-49104	40	27	123-40808	14	50
SS-7110840-SP	6	45	WP-0621016-SD	12	63	119-49807	12	65	123-40907	14	35
SS-7110840-SP	6	46	WP-0651056-SD	26	22	119-59400	27	21	123-41806	27	6
SS-7110840-SP	14	34	WP-0671016-SE	30	36	119-59558	28	15	123-41806	27	16
SS-7110840-SP	14	36	WP-0751576-SD	4	25	119-60655	30	1	123-41806	28	25
SS-7110840-SP	16	28	WP-0764016-SP	6	13	119-60754	30	13	123-41905	27	5
SS-7110840-SP	22	36	WP-0850002-SC	28	30	119-64509	40	14	123-41954	27	4
SS-7110840-SP	24	24	WP-0871602-SE	30	11	119-65704	40	18	123-42101	2	11
SS-7110910-TP	10	17	WP-0871602-SE	30	23	119-65753	40	16	123-47167	22	9
SS-7111410-TP	6	32	WP-0871602-SE	30	30	119-65803	40	19	123-47266	22	10
SS-7111410-TP	6	36	WP-1002036-SE	27	28	119-92005	40	15	123-47308	41	6
SS-7111410-TP	6	40	WP-1002036-SE	28	39	119-99307	14	13	131-00805	2	16
SS-7111410-TP	16	29	WP-1612616-SE	32	25	120-15301	22	39	131-00904	2	15
SS-7111810-TP	6	11	WP-1612616-SE	34	27	120-15400	22	40	131-01001	2	21
SS-7111810-TP	6	29	WP-1612616-SE	36	26	121-02208	22	16	131-01209	2	18
SS-7111810-TP	6	31	WS-0510002-KN	32	29	121-02810	22	23	131-01308	2	30
SS-7111810-TP	6	35	WS-0510002-KN	34	31	121-02950	22	31	131-01407	2	19
SS-7111810-TP	6	39	WS-0510002-KN	36	30	121-03107	22	29	131-01506	2	25
SS-7111810-TP	6	44	WS-0510002-KN	38	32	121-03305	2	28	131-01605	2	26
SS-7150740-SP	16	45	WS-0510002-KN	38	32	121-03701	22	18	131-01803	2	32
SS-7151120-SP	22	30	WS-0621210-KR	30	35	121-04550	40	22	131-01902	2	36
SS-7161040-SP	16	48	WS-0822010-KP	4	26	121-05458	40	21	131-02058	2	35
SS-8080310-TP	8	65	WS-0861410-KR	30	29	121-09153	6	28	131-02207	2	45
SS-8080310-TP	8	67	WS-1002560-KR	27	29	121-16604	10	18	131-02405	2	3
SS-8080322-TP	40	1	WS-1002560-KR	28	36	121-16703	10	19	131-02504	4	20
SS-8080322-TP	40	2	WS-1643202-KR	32	26	121-16802	10	20	131-02553	4	19
SS-8090530-TP	8	57	WS-1643202-KR	34	28	121-16901	10	21	131-02603	4	23
SS-8090530-TP	8	59	WS-1643202-KR	36	27	121-17008	10	22	131-02702	22	46
SS-8110410-TP	2	23	WS-1643202-KR	38	29	121-18204	12	10	131-02900	4	38
SS-8110410-TP	2	24	WZ-0420350-KP	2	37	121-18303	12	9	131-03650	2	34
SS-8110410-TP	10	11	WZ-0420350-KP	40	24	121-20150	6	38	131-03809	2	13
SS-8110410-TP	12	44	WZ-0640312-KO	20	43	121-20705	15	11	131-03908	4	24
SS-8110410-TP	20	17	WZ-0850302-KO	4	30	121-20713	40	4	131-04005	2	1
SS-8110520-TP	16	30	WZ-2640310-KH	6	15	121-21612	15	34	131-04104	2	51
SS-8151150-TP	6	5				121-22362	6	30	131-04203	2	2
SS-8660330-SP	12	32	107-53309	4	39	121-23360	6	34	131-04302	2	44
SS-8660330-SP	23	23	111-51065	30	26	121-23659	14	24	131-04500	4	10
SS-8660610-TP	8	56	111-51909	30	31	121-23709	40	7	131-04807	4	29
SS-8660610-TP	14	61	111-55108	27	19	121-29805	26	20	131-04906	6	20
SS-8660610-TP	14	64	111-55108	28	32	121-29904	26	18	131-07602	6	4
SS-9090410-TP	14	43	111-55207	27	20	121-32155	6	43	131-07701	6	10
SS-9090610-TP	14	42	111-55207	28	33	121-32619	22	15	131-07800	6	6
SS-9090823-TP	23	19	111-57567	30	2	121-32700	22	20	131-08006	6	23
SS-9111010-SP	12	3	111-59001	30	6	121-32809	22	26	131-08105	6	24
SS-9111010-SP	22	21	111-59001	30	18	121-32908	22	24	131-08204	6	25
SS-9111050-SP	12	51	111-59365	30	14	121-33005	22	27	131-08303	6	27
SS-9111610-SP	40	47	112-46501	30	38	121-33104	22	22	131-08402	6	8
SS-9112310-SP	40	50	112-46600	30	37	121-33211	22	11	131-08501	6	9
SS-9151210-TP	14	6	115-01301	40	23	121-52468	40	30	131-10002	8	15
SS-9151210-TP	14	9	115-44707	40	5	121-53763	18	35	131-10101	8	5

NUMERICAL INDEX OF PARTS

索引

PART NO 品番	PAGE 頁	REF NO	PART NO 品番	PAGE 頁	REF NO	PART NO 品番	PAGE 頁	REF NO	PART NO 品番	PAGE 頁	REF NO
131-10200	8	22	131-22809	12	24	131-42955	26	33	131-67853	38	1
131-10259	8	21	131-23302	12	39	131-43300	26	29	131-67903	32	8
131-10507	8	2	131-23302	16	44	131-43417	26	43	131-67903	34	9
131-10556	8	1	131-25901	15	13	131-43508	26	44	131-67903	36	9
131-10606	8	4	131-25950	15	12	131-43607	26	47	131-67903	38	9
131-10705	8	24	131-26008	15	4	131-43706	26	48	131-68000	32	9
131-10804	8	25	131-26354	15	9	131-43805	26	27	131-68000	34	10
131-10903	8	26	131-26503	15	19	131-44001	26	30	131-68000	36	10
131-11000	8	27	131-26602	15	20	131-44100	26	39	131-68000	38	10
131-11109	8	31	131-26701	15	21	131-44209	26	40	131-68109	32	10
131-11208	8	34	131-26800	15	22	131-47301	23	9	131-68109	34	11
131-11307	8	35	131-26909	15	3	131-47400	23	7	131-68109	36	11
131-11406	8	36	131-27006	15	17	131-47509	23	2	131-68109	38	11
131-11505	8	38	131-27105	15	18	131-47558	23	1	131-68208	32	11
131-11604	8	39	131-27204	15	23	131-50503	23	17	131-68208	34	12
131-11703	8	40	131-27303	15	24	131-50602	23	18	131-68208	36	12
131-15001	16	1	131-27402	15	25	131-50701	22	45	131-68208	38	12
131-15100	16	2	131-27501	15	26	131-50800	23	11	131-68307	36	31
131-15209	16	4	131-28103	15	16	131-50909	23	5	131-68356	36	3
131-15258	16	3	131-28202	20	31	131-51006	23	6	131-68406	34	16
131-15407	16	8	131-28301	20	32	131-51105	22	35	131-68406	38	18
131-15654	16	32	131-28400	20	33	131-51204	22	5	131-68505	34	3
131-15753	16	9	131-28509	20	34	131-51303	23	4	131-68505	38	3
131-15803	16	10	131-28608	20	35	131-55007	27	15	131-68802	34	4
131-15902	16	11	131-28707	20	36	131-55106	28	17	131-68802	38	4
131-16009	16	12	131-28905	20	37	131-55205	28	18	131-68851	34	2
131-16108	16	13	131-29101	20	40	131-55304	28	27	131-68851	38	2
131-16207	16	18	131-29200	20	41	131-55403	27	13	131-68901	38	36
131-16306	16	20	131-29309	14	21	131-55403	28	16	131-68950	38	19
131-16405	16	22	131-29309	15	7	131-55502	27	10	131-70006	4	9
131-16504	16	23	131-29457	20	38	131-55502	28	22	131-70105	4	21
131-16603	16	24	131-29853	15	1	131-55601	27	8	131-70204	4	11
131-16702	18	2	131-29903	15	6	131-55601	28	20	131-70204	12	34
131-16801	16	7	131-29952	15	5	131-55700	27	9	131-70303	6	14
131-16900	16	21	131-31008	14	5	131-55700	28	21	131-70402	16	36
131-17007	16	19	131-31057	14	4	131-55759	27	7	131-70402	16	37
131-17106	16	34	131-31107	14	8	131-55759	28	19	131-70501	12	48
131-18054	10	1	131-31156	14	7	131-55858	28	5	131-70600	14	17
131-18708	10	16	131-31206	14	37	131-55908	28	8	131-70808	26	34
131-19300	10	14	131-31305	14	38	131-56005	28	9	131-71004	4	22
131-19409	10	23	131-31404	14	39	131-56104	28	10	131-72507	10	10
131-19508	10	24	131-31503	14	40	131-56203	28	6	131-72556	10	9
131-19607	10	25	131-31602	14	41	131-56302	28	7	131-72705	8	55
131-19706	10	39	131-31701	14	44	131-56500	27	14	131-72754	8	54
131-19805	10	42	131-31800	14	46	131-60007	41	2	131-72804	14	60
131-19904	10	33	131-31909	14	45	131-60106	41	7	131-72804	14	63
131-19953	10	32	131-32006	14	47	131-60205	41	3	131-72853	14	59
131-20001	10	41	131-32501	14	20	131-60304	41	8	131-72853	14	62
131-20605	10	2	131-32550	14	19	131-60403	41	9	131-72903	2	38
131-20803	12	33	131-32709	14	56	131-60601	41	11	131-75005	8	62
131-20902	12	29	131-37559	20	2	131-60700	4	43	131-78306	18	18
131-21009	12	31	131-37609	20	12	131-60858	41	1	131-78306	18	33
131-21058	12	30	131-37708	20	8	131-60908	27	2	131-78306	40	44
131-21108	12	52	131-37807	20	5	131-60908	28	2	131-78405	18	47
131-21207	12	43	131-37906	20	13	131-61005	27	1	131-91309	12	70
131-21256	12	42	131-38003	20	16	131-61005	28	1	131-91408	12	71
131-21306	12	40	131-38102	20	14	131-61153	27	3	131-91606	12	64
131-21405	12	26	131-38201	20	15	131-61153	28	26	131-92406	12	66
131-21603	12	49	131-38201	20	27	131-62557	24	6	131-92802	12	67
131-21900	12	45	131-38359	20	3	131-62565	24	7	131-93206	12	68
131-22007	8	49	131-38409	20	9	131-62573	24	8	131-93602	12	69
131-22007	10	35	131-38508	20	6	131-62805	24	9	132-00209	4	1
131-22007	23	13	131-38656	20	4	131-62805	24	18	132-00308	4	2
131-22106	8	50	131-38706	20	10	131-62904	24	11	132-00506	4	5
131-22106	10	36	131-38805	20	7	131-62904	24	20	132-00605	4	6
131-22106	23	14	131-38904	20	11	131-63001	24	12	132-00704	2	7
131-22205	8	51	131-39555	20	20	131-63001	24	21	132-00803	2	8
131-22205	10	37	131-39605	20	22	131-63159	24	15	132-00902	12	54
131-22205	23	15	131-39704	20	25	131-63167	24	16	132-01009	4	12
131-22304	8	52	131-39803	20	24	131-63175	24	17	132-01108	4	28
131-22304	10	38	131-39902	20	23	131-63456	24	1	132-01207	4	33
131-22304	23	16	131-40009	20	21	131-63803	24	2	132-01306	4	32
131-22403	10	5	131-42500	26	25	131-63902	24	3	132-01405	4	16
131-22452	10	4	131-42500	41	16	131-67556	32	1	132-01454	4	15
131-22502	10	13	131-42609	8	48	131-67655	36	1	132-01504	2	41
131-22700	12	18	131-42609	26	38	131-67754	34	1	132-01603	2	42

NUMERICAL INDEX OF PARTS

索引

PART NO 品番	PAGE 頁	REF NO	PART NO 品番	PAGE 頁	REF NO	PART NO 品番	PAGE 頁	REF NO	PART NO 品番	PAGE 頁	REF NO
132-04003	4	35	132-30305	26	1	400-23234	6	2			
132-05406	6	19	132-35304	22	19	400-23235	6	1			
132-07808	8	20	132-40007	2	43	400-25294	40	56			
132-08004	8	68	132-40106	2	49	400-30533	18	34			
132-08103	8	17	132-40205	2	50	400-30533	40	64			
132-08350	8	16	132-44009	8	46	400-35711	6	48			
132-08459	8	42	132-44108	10	30	400-36778	40	63			
132-08509	8	43	133-43009	26	4						
132-08608	8	47									
132-08707	8	30	229-01805	4	37						
132-08806	8	28	229-21407	20	25						
132-08905	8	29	229-24708	4	8						
132-09101	8	9	229-30309	32	12						
132-09200	8	10	229-30309	34	13						
132-09309	8	11	229-30309	36	13						
132-09408	8	12	229-30309	38	13						
132-09507	8	13	229-30408	32	6						
132-09606	8	14	229-30408	34	7						
132-09705	8	19	229-30408	36	7						
132-09804	8	7	229-30408	38	7						
132-09853	8	6	229-30507	32	3						
132-12501	16	39	229-30507	36	4						
132-12600	16	31	229-30556	32	2						
132-12709	16	35	229-30556	36	2						
132-12808	16	41	229-30705	32	4						
132-12915	16	43	229-30705	34	5						
132-13012	12	38	229-30705	36	5						
132-13012	16	42	229-30705	38	5						
132-15157	12	1	229-30804	32	16						
132-15306	12	4	229-30804	34	17						
132-15405	12	5	229-30804	36	17						
132-15504	12	6	229-30804	38	17						
132-15603	12	7	229-30903	32	15						
132-15702	12	11	229-30903	34	16						
132-15801	12	17	229-30903	36	16						
132-15900	12	13	229-30903	38	16						
132-16007	12	14	229-31000	32	14						
132-16106	12	19	229-31000	34	15						
132-16205	12	21	229-31000	36	15						
132-16304	12	23	229-31000	38	15						
132-16601	10	28	229-31109	32	13						
132-16700	10	29	229-31109	34	14						
132-16809	10	26	229-31109	36	14						
132-17351	12	47	229-31109	38	14						
132-17401	12	57	229-31307	32	7						
132-17500	12	58	229-31307	34	8						
132-17708	12	36	229-31307	36	8						
132-17807	10	12	229-31307	38	8						
132-17906	10	31	229-31406	32	5						
132-18052	12	50	229-31406	34	6						
132-18102	12	56	229-31406	36	6						
132-20009	15	15	229-31406	38	6						
132-21403	14	66	229-32800	41	4						
132-21502	14	67	229-33006	41	12						
132-21601	14	68	229-33105	41	5						
132-21700	14	69	229-33303	41	13						
132-21809	14	70	236-30007	8	45						
132-21908	14	71	236-30007	26	54						
132-22203	14	52									
132-22302	14	53	310-18005	26	56						
132-22401	14	29	310-18005	26	60						
132-22609	14	2									
132-22708	14	3	400-10804	14	55						
132-25008	20	1	400-10805	15	10						
132-25107	20	18	400-11234	14	72						
132-25107	20	19	400-11755	40	57						
132-28655	26	23	400-11757	40	58						
132-28804	26	55	400-11758	40	62						
132-28903	26	59	400-15637	14	10						
132-29000	26	61	400-16762	26	12						
132-29109	26	57	400-16763	26	16						
132-29208	26	51	400-16841	14	11						
132-29307	26	19	400-17714	6	47						
132-29356	26	17	400-17824	6	41						
132-29406	26	58	400-18044	26	2						
132-30107	26	45	400-22255	40	59						

JUKI®

JUKI 株式会社

JUKI CORPORATION

お問い合わせ、ご相談は
To order or for further
information,
please contact :

Copyright © 2002–2006 JUKI CORP.
本書の内容を無断で転載、複写すること
を禁止します。
All rights reserved throughout the world.

※このパーツリストは商品改良のため予告なく変更する事があります。
*The description covered in this parts list is subject to change for improvement of the commodity without notice.
※このパーツリストは、2006年3月 現在の商品仕様で編集したものです。
*This parts list is edited in accordance with the product specifications as of March 2006.